

# Boomer Manual



David Bourne

---

*V 3.3.5 - July 2010*  
*Copyright © David Bourne 2010*

# Boomer Manual



David Bourne

---

*V 3.3.5 - July 2010*  
*Copyright © David Bourne 2010*

Boomer .....	6
1. Background .....	7
2. Fitting Algorithms .....	8
Gauss-Newton.....	8
Damping Gauss-Newton.....	8
Modified Marquardt .....	8
Simplex .....	8
Simplex -> Damping Gauss-Newton.....	8
Grid Search.....	8
3. Numerical Integration Algorithms.....	10
Classical Fourth Order Runge-Kutta.....	10
Runge-Kutta-Gill .....	10
Fehlberg RKF45 .....	10
Adams Predictor-Corrector .....	10
Gear with PEDERV subroutine.....	10
Gear without PEDERV subroutine .....	10
4. Instructions for Boomer .....	11
Data Entry .....	11
B. Method of Analysis .....	12
D. Model definition - Boomer.....	17
E. Specifying Parameter Values and Limits.....	28
F. Example Models - Boomer.....	30

H. Numerical Integration Method.....	31
I. Numerical Integration - Error Terms.....	33
J. Fitting Algorithm .....	33
K. Fitting Criteria .....	34
L. Data Set Title .....	34
M. Individual Data Value Entry .....	34
N. Weighting Scheme.....	35
O. Entry of Initial Parameter Estimates .....	36
P. Simulation with Error Input.....	37
Q. AUC, AUMC, and MRT.....	38
R. Additional Output including Saving Data, Graphs, Extra Files and Sensitivity Ouput .....	38
S. Notes .....	43
5. Output Information .....	44
6. Boomer Tutorial.....	47
A. Normal Fitting - Two Compartment I.V. Bolus Model.....	47
B. Bayesian Analysis - I.V. Infusion with kel function of Creatinine Clearance.....	50
C. Working with Batch (.BAT) files - Simulation .....	53
D. Simultaneous Fit to IV and Oral Data - IRWLS .....	55
E. Simulation with Error and Monte-Carlo Simulations.....	56
F. Grid Search Method.....	57
7. Error Messages.....	59
A. FORTRAN error messages.....	59

B. RKF45 error messages .....	59
E. DIFSUB error messages.....	60
8. Acknowledgments .....	61
9. Applications.....	62

# Boomer

## *Non-linear Regression Programs for the Analysis of Pharmacokinetic and Pharmacodynamic Data*

David W.A. Bourne, OU College of Pharmacy, 1110 N. Stonewall Ave., Oklahoma City, OK  
72117 U.S.A.

Copyright © 1986-2010 David W.A. Bourne



---

[A Boomer](#)

July 2010 - Version 3.3.5

**References:** - [[Bourne, 1986](#); [Bourne, 1989](#)]

# 1. Background

MULTIFORTE started as a direct FORTRAN 77 translation of the MULTI program written in BASIC by K. Yamaoka *et.al* [[Yamaoka, 1981](#)].

MULTI was written for a microcomputer in BASIC and allowed for the nonlinear least squares analysis of integrated equations. The four fitting algorithms were included in this original program. Later versions of MULTI incorporated Bayesian fitting and numerical integration of differential equations as separate programs [[Yamaoka, 1983](#); [Yamaoka, 1985](#)].

MULTIFORTE includes normal fitting, Bayesian estimation, or simulation only with integrated or differential equation models in the one program. Also, the selection of weighting schemes and methods for numerical integration has been expanded. With MULTIFORTE the pharmacokinetic model is written in FORTRAN 77, compiled and linked with the rest of the program.

BOOMER was developed with the same fitting and numerical integration routines found in MULTIFORTE. However, with BOOMER the model is described using model parameters (based on the approach used by SAAM v23).

# 2. Fitting Algorithms

## GAUSS-NEWTON

This is a method based on expanding the model equation(s) of interest in a Taylor series [[Hartley, 1961](#)].

## DAMPING GAUSS-NEWTON

The correction term applied to the 'old' parameter values is reduced by a factor of two if the 'new' parameter values result in a worse value for WSS. This is allowed up to 25 times during each iteration, although rounding error may become significant above 15 reductions.

## MODIFIED MARQUARDT

The Marquardt method is intermediate between the Taylor series (Gauss-Newton) method and the method of steepest descent (gradient method). In the method of steepest descent the new parameter values are calculated in the direction of the negative slope of the WSS with respect to each of the parameters. Marquardt has suggested that the direction of change in parameters calculated by these two methods is not always in the same direction. Marquardt's method attempts to find a best compromise [[Marquardt, 1963](#)].

This method as used in MULTI and MULTI-FORTE has been further modified by Flecher [[Flecher, 1971](#)].

## SIMPLEX

The simplex method of Nelder and Mead is the fourth option. This method involves the progression of a moving simplex across the WSS surface. Typically the worst point of the simplex is projected across the center (centroid) of the simplex to a better value. There are a series of simple rules to move the simplex to the WSS minimum. It is a relatively robust (but slower) method [[Nelder, 1965](#)].

In MULTI (line 3500) one of the rules was altered slightly. This rule was changed back to the Nelder-Mead version in MULTI-FORTE and BOOMER.

## SIMPLEX -> DAMPING GAUSS-NEWTON

The Simplex method is quite robust and can be used with less accurate initial parameter estimates. However, it is not possible to estimate parameter value variances by this method. Thus it may be useful to automatically proceed from the final Simplex values to the input stage of another method. Presently that other method is the Damping Gauss-Newton.

## GRID SEARCH

By specifying upper and lower parameter limits as well as the number of grids, it is possible to calculate the weighted sum of squares at each grid intersection. The results of this analysis can

be output to disk for incorporation into a 3-D graphing program such as DeltaGraph Pro<sup>®</sup> (Macintosh graphing program).

# 3. Numerical Integration

## Algorithms

### CLASSICAL FOURTH ORDER RUNGE-KUTTA

This method is an implementation of the fourth order Runge-Kutta method. A relative error term is used to adjust the step-size. Error control is achieved by simply halving the step size until the change in calculated values is smaller than the error requested [[Kutta, 1901](#)].

### RUNGE-KUTTA-GILL

This is the numerical integration method used in MULTI(RUNGE) by Yamaoka *et.al*. It has also been modified to give automatic step-size control. Again, error control is achieved by halving the step size until the desired accuracy is achieved. In MULTI(RUNGE) the step size was adjusted manually [[Gill, 1951](#)].

### FEHLBERG RKF45

This is a further modification of the Runge-Kutta fourth order method which uses a fifth order calculation to determine the appropriate step size given values for the required relative and absolute error. This is the subroutine written by Watts and Shampine and published as Subroutine RKF45 in the book by Forsythe, Malcolm, and Moler [[Fehlberg, 1969](#); [Watt, 1977](#); [Shampine, 1977](#)]. This method is very efficient and appears to be the method of choice for non-stiff systems of differential equations.

### ADAMS PREDICTOR-CORRECTOR

This is one of the options of the subroutine written by Gear. This method is also for non-stiff systems of differential equations. Step-size and order are automatically controlled to achieve a user defined absolute error [[Gear, 1969](#); [Gear, 1971a](#); [Gear, 1971b](#)].

### GEAR WITH PEDERV SUBROUTINE

This is the most efficient option for use with stiff equations. The subroutines DECOMP and SOLVE were modified from those presented in the text by Forsythe and Moler [[Forsythe, 1967](#)].

### GEAR WITHOUT PEDERV SUBROUTINE

The partial derivatives are calculated by numerical differencing thus a user supplied PEDERV subroutine is not required.

# 4. Instructions for Boomer

After starting Boomer you should see the title, copyright information, and references to the original MULTI.

The method of data entry is then chosen from the menu option.

## DATA ENTRY

- 0) From KEYBOARD
- 1) From .BAT file
- 2) From KEYBOARD creating .BAT file
- 3) From .BAT file (quiet mode)
- 4) to enter data only
- 9) to quit
- 1) From .BAT file (with restart)
- 3) From .BAT file (quiet mode-with restart)
- 5) to calculate AUC from a .DAT file
- 8) Registration Information

Data can be entered from the keyboard or from a batch file (verbose (1) or quiet (3) modes). Alternately a batch file can be prepared while entering the data from the keyboard.

Boomer is started (Mac OS X and DOS version) from the command line using the command  
`boomer filename quiet mrun`

where filename is the BAT filename, quiet (or 3, q or Q) indicates quiet mode, and mrun is the maximum number of runs in multi run mode.

## DATA ENTRY

### *0) From keyboard*

All subsequent data will be entered from the keyboard.

### *1) From .BAT file*

Subsequent data will be read from the batch file (named xxx.BAT). Only the xxx part of the name should be entered as the program will add the .BAT extension. As with later filename entries the extension is not to be entered.

```
Boomer is looking for -> xxxx.BAT <- Do you have the right file name?
```

```
PAUSE Filename incorrect - try again? statement executed  
To resume execution, type go. Other input will terminate the job.
```

If a batch file (named xxx.BAT) has been prepared the data can be read from this file instead of from the keyboard. Only the xxx part of the name should be entered as the program will add the .BAT extension. As with later filename entries the extension is not to be entered. DOS version. If the file is not found (or spelled incorrectly) a PAUSE message is displayed which allows the user to enter a DIR or other DOS command.

```

Enter .BAT filename noname
Filename incorrect - Enter DIR or <cr>
dir *.bat
...
directory here
...
Enter .BAT filename testb
The input .BAT filename is testb .BAT

```

For example, DIR\*.BAT would display all the .BAT files in the current directory. The directory or drive could be changed with a CD xxx or A: type command. This is then followed by another request for the file name (less extension).

### *-1) From .BAT file with Restart Option*

If a numerical integration method (especially RKF or Gear) is used with fitting problems it is possible that parameter values may be tried which cause 'unstable' integration with the program stopping. With Restart ON (checked) it is possible for the program to restart automatically using parameter values which are stored to disk during the iteration process (in a file called Scratch.PAR). This option is especially useful with unattended operation using large systems of differential equations. The current best parameter values are stored periodically as Scratch.PAR.

### *2) From keyboard creating .BAT file*

Again a .BAT file name is requested. Data will be entered from the keyboard and used both in the analysis and to create a .BAT batch file. Be careful not to use the name of a .BAT file previously created and needed later. The program will check to confirm that you want to overwrite files having the same name.

### *3) From .BAT file (quiet mode)*

Subsequent data will be read from the batch file (named xxx.BAT). In this mode subsequent data entry is not displayed on the screen. This can result in faster operation.

### *-3) From .BAT file with Restart Option (quiet mode)*

### *4) to enter data only*

This choice allows the user to enter data into a xxx.DAT file for subsequent analysis.

### *5) to calculate AUC from a .DAT file*

This choice allows the user to calculate AUC from data in a xxx.DAT file.

## **B. METHOD OF ANALYSIS**

### **METHOD OF ANALYSIS**

- 0) Normal fitting
- 1) Bayesian
- 2) Simulation only
- 3) Iterative Reweighted Least Squares
- 4) Simulation with random error or sensitivity analysis
- 5) Grid Search

- 5) To perform Monte Carlo run (Start of BAT file)
- 4) To perform multi-run (End of BAT file)
- 3) To run random number test subroutine
- 2) To close (or open) .BAT file
- 1) To finish

Enter choice (-3 to 5)

### 0) *Normal*

This option allows a normal weighted non-linear regression analysis of the data set.

### 1) *Bayesian*

A Bayesian analysis is also possible. The observed data may be weighted. During data entry population mean and standard deviations are required for each adjustable parameter.

### 2) *Simulation only*

This option is useful for models consisting of large systems of differential equations. That is, systems taking a long time to solve or for which fitting is not required. This option could be useful in the analysis of systems containing fast and slow rate constants (so-called 'stiff equations'). These are commonly observed with physiological models.

### 3) *Iteratively Reweighted Least Squares*

With this option the weighting functions use the calculated 'y' value at each stage of the fitting rather than the observed 'y' values. For example using a 1/value weighting function with option results in a weight calculated as 1/y<sub>calc</sub>, not 1/y<sub>obs</sub>. This can reduce some of the strange fitting that results when very small 'y' observed values are included in a data set. These values may be given a weight much larger than they really deserve [[Peck, 1984a](#); [Peck, 1984b](#)].

### 4) *Simulation with random error or sensitivity analysis*

This option allows the simulation of data sets with added error. The error can be calculated as proportional or independent of the y-value and can be calculated as uniformly distributed or normally distributed. Log normal or exponential error can also be added to data. This same uniform, normal, log normal and exponential error can be randomly applied to any of the parameter values. See section Q, below, for more details. A repeat (Monte Carlo) option will allow a large number of simulations to be run, creating different data sets with each run.

In the sensitivity (or optimal sampling) mode the program generates graphs of y-value sensitivity to each of the adjustable parameters. Each point of maximum sensitivity (in a 100 step increment) is also reported. The program calculates the sensitivity value, calculated using the equation below for each parameter.

$$\left[ \frac{100 \bullet (C_{p_{Pi \bullet 1.005}} - C_{p_{Pi \bullet 0.995}})}{P_i} \right] \bullet \sqrt{wt}$$

The time when this value is maximum can be used as an optimal sampling time.

### 5) *Grid search method*

This option allows a systematic search of a specified parameter space. The space is defined by specifying upper and lower limits and the number of steps in the grid. Output can be in the normal form or as disk files of parameter values and weighted sum of squares values for input into a graphing program for 3-D surface plotting. The Macintosh version will automatically create gnuplot control files and create a QuickTime™ movie of the surfaces.

### -5) *Monte Carlo run*

This is similar to the multi run option below with one significant difference. If data files are input or output they will be created with unique (incremental) names. They can be useful in the generation of many multiple data sets that might be useful as a clinical trial simulation. A Monte Carlo run .BAT file can also be created from a 'ordinary' .BAT file by adding the number of runs (>10) as the second line in the .BAT file.

#### Monte Carlo run Option

It is possible to run repeated analyzes of 10 to 99999 data sets (memory and time permitting). This could be be useful in a Monte Carlo type analysis. I have found this useful for generating homework data sets. It could also be used to simulate data sets for other purposes such as clinical trial simulations. An additional output data file (extension .NDT) is generated with the same name as the 'normal' output (.OUT) file but in NONMEM input data file format.

These runs can be set-up during the creation of the .BAT file as above or by creating a single run batch files as normal with -2 at the end. Open the .BAT file in a text editor and insert above the first data line the number of repeats required (must be greater than 10).

Boomer Batch File

4

wls,bayes,sim,irwls,sim+error,grid

Top of the .BAT file before editing and

Boomer Batch File

25

4

wls,bayes,sim,irwls,sim+error,grid

after editing to simulate 25 data sets.

Save the file and select batch file run. When simulating data sets use the simulate with error option to make different data sets on each run. When saving the calculated data set (the first time

through when creating the batch file) use any reasonable, short file name (e.g. test: A maximum of 4 characters are used with the DOS version). In repeat mode the program will create file names with a numbered extension. For example test0001.DAT, test0002.DAT, test0003.DAT ... in sequence. When reading the data sets in using the repeat option the same naming convention is used. That is specify 'test' and the program will expect to read files test0001.DAT, test0002.DAT, test0003.DAT etc. [There are four columns in the number field to accommodate file names from test0001.DAT to test9999.DAT].

The auxiliary program cDAT can read these multiple DAT files and combine them into a tab delimited summary file suitable for importing into Excel(R) or [OpenOffice](#). The cDAT program is installed by the Mac OS X boomer installation package in /usr/bin. The program can be invoked by typing cDAT and then providing the DAT file name and the number of files. It can also be invoked as one command.

```
cDAT test nnn
```

where 'test' is the first part of the DAT file name (can be entered as test0001 or the complete name test0001.DAT) and 'nnn' is the number of DAT files.

The auxiliary program eOUT can extract specified lines from .OUT files (especially useful for Monte Carlo or Multi runs), optionally converting spaces to tabs. The output file is suitable for importing into Excel(R) or [OpenOffice](#). The eOUT program is installed by the Mac OS X boomer installation package in /usr/bin. The program can be invoked by typing eOUT and then providing the OUT file name and other parameters. It can also be invoked as one command.

```
eOUT test.OUT key nskip nline tflag
```

where test.out is the .OUT file name (test should also work), key is the string to search (enclose with " if it contains spaces), nskip is the number of lines to skip after key is found, nline is the number of lines to export and tflag is 0 or 1 (if equal to 1 converts run of spaces to one tab). It is useful to examine the .OUT file before running eOUT to determine the best values of the parameters, especially key, nskip and nline.

The auxiliary program eBEST can extract the best run from a multi-run .OUT file. The eBEST program is installed by the Mac OS X boomer installation package in /usr/bin. The program can be invoked by typing eBEST and then providing the OUT file name. It can also be invoked as one command.

```
eBEST test.OUT
```

where test.out is the .OUT file name. The program then asks

```
Enter percent from Best WWW
```

Enter a percent (x) and the program displays the number of runs with a WSS within x% of the best. The best run is placed in a file BEST.OUT which is opened by BBEdit (Macintosh if installed) or NotePad (Windows) for review and saving. eBest also provides the file eBestP.OUT containing the WSS and parameter values for each run.

#### *-4) Multi run*

This option allows either repeated runs of the BAT file or chaining to another BAT file. It will not be selected initially but only at the end of the first run. Repeatedly running a BAT file is useful when fitting data using the Simplex method as each run starts with a randomly generated simplex. A multi run .BAT file can be created from a 'ordinary' .BAT file by changing the -1 or -2 on the last line to -4 and entering the .BAT file name on the following line.

#### *-3) Random Number Test*

The Macintosh toolbox routine, random, is used to generate random numbers for the simplex method (to create the starting simplex), and the simulation with error values. This option gives the user the opportunity of testing these random numbers. The numbers are output to disk files. Random produces uniformly random numbers (URN) in the range -32,768 to 32,767 which are scaled to real numbers between the value of 0.0 and 1.0. Normally distributed random numbers (NDRN) with mean of zero and standard deviation of one are calculated using the equation [[Abramowitz, 1964](#), page 953]:

$$NDRN = \sum_{n=1}^{n=12} URN_i - 6.0$$

#### *-2) To close (or open) batch files*

This option allows the user to break a batch file run down into smaller parts. Each batch file could then be combined in the editor. Alternately the first data set could be analyzed using the make batch file mode and closed with a -2 without exiting the program. The editor could then be used to edit this newly created batch file to analyze the remaining data sets. A -2 is put on the end of any batch file created. Batch files can be chained by manually editing the .BAT file with the editor. Replace the -1 or -2 at the end of the batch file with a -4. On the next line put the name of the batch file you want to run next. Enter the name without the .BAT extension. Make sure that there is a carriage return after the .BAT file name. All output will go to the .OUT file specified in the first .BAT files.

#### *-1) To finish the program*

All normally finishing runs will come back to this choice. If no further analyses are required a -1 is entered. With a batch file run this -1 is put on the last line of the batch file in the expected sequence. If editing a batch file remember to ensure that a carriage return must be present in the

batch file after the -1 for it to be correctly interpreted. Actually all batch, data, or model files must end with a carriage return to be interpreted correctly.

## C. Output options

Where do you want the output?

- 0) Terminal screen
- 1) Disk file

Enter choice (0-1)

### 0) Terminal screen

All output is directed to the computer terminal screen. This is useful for a quick check of the input data or for rapid analysis which doesn't need to be kept.

### 1) Disk file

Again a disk file name is requested after selecting this option. The final results and requested plots can be directed to an .OUT file output file for later printing or enhancement. The output is saved as a text type file which could be read into a word processor for editing or other visual enhancement. This option can be particularly useful for receiving the results from a large series using batch input if there is any problem with a printer jamming while unattended. Of course the disk receiving a large output file will need to have enough space.

## D. MODEL DEFINITION - BOOMER

One limitation of the original implementation of MultiForte was that the user had to have and know how to use the Fortran compiler in order to study different pharmacokinetic models. This is still an option with the original version of MultiForte. Boomer, a version of Multi-Forte described in this section, allows the user to describe a model in terms of time interrupts (e.g. dose times or lag times), dose, first order rate constants, zero order rate constants, constants, Michaelis-Menten kinetics elimination rate systems [[Portmann, 1970](#); [Michaelis, 1913](#)], multipliers (i.e. inverse apparent volumes of distribution), sums of exponentials, Hill equation components [[Rubinow, 1975](#); [Hill, 1910](#)], second order rate constants, or simple physiological models [[Duddy, 1984](#)]. This building of a model is similar to the approach taken with the mainframe simulation and modeling program, SAAM [[Berman, 1968](#)].

MODEL Definition and Parameter Entry                      \* Allowed Parameter Types \*

- |   |                                    |                        |
|---|------------------------------------|------------------------|
| -5) read model                              | -3) display choices                | -2) display parameters |
| 0) Time interrupt                           | 1) Dose/initial amount             | 2) First order rate    |
| 3) Zero order                               | 4-5) Vm and Km of Michaelis-Menten |                        |
| 6) Added constant                           | 7) Kappa-Reciprocal volume         |                        |
| 8-10) $C = a * EXP(-b * (X-c))$             |                                    |                        |
| 11-13) Emax (Hill) Eq with Ec(50%) & S term | 14) Second order rate              |                        |



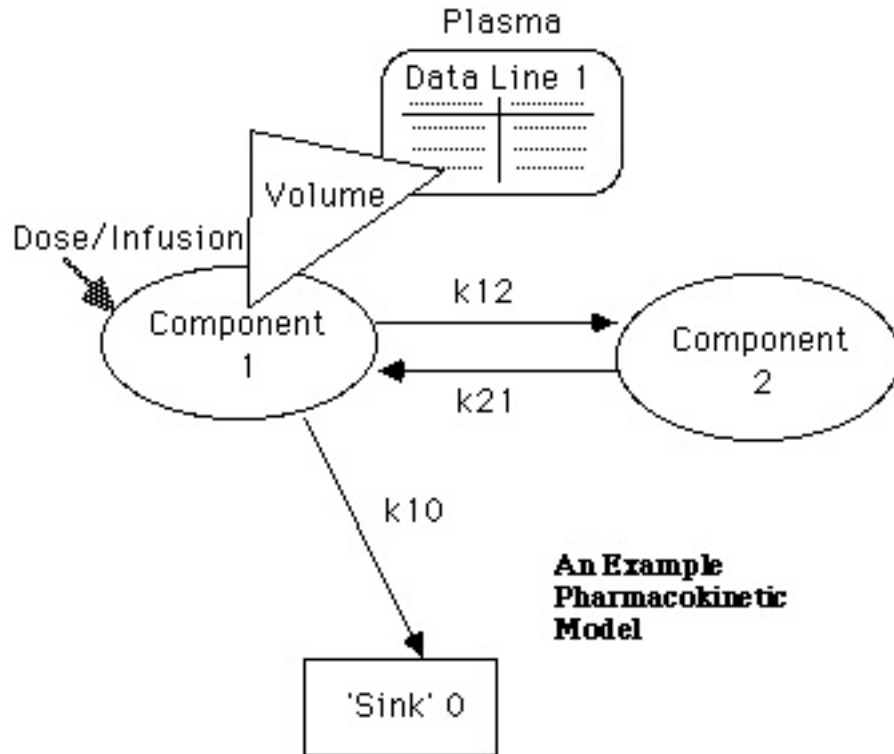

## 2) *First order rate constant*

By specifying various rate constants it is possible to build a system of differential equations for simulation of the model required.

The model, shown above, would involve three first order rate constants,  $k_{10}$ ,  $k_{12}$ , and  $k_{21}$ . Each of these first order rate constants could be specified by name ( $k_{10}$ ), value, component to receive flux (0) and component to lose flux (1). In this model drug would flow from the central compartment (Component 1) to the outside world (the 'sink' designated as Component 0). The remaining rate constants can be specified in a similar manner. The data entry for  $k_{12}$  is shown below. Connection between the components of the model (specifically component 1) and the data to be fitted or simulated is made with the volume term. In this case the plasma data is equal to the amount in component 1 divided by the volume (of distribution).

```

Enter -3 to see choices, -1 or -4 (save model) to exit this section
Enter type# for parameter 2 (-5 to 43) 2
Enter parameter name k12
Enter k12 value 0.13
0) fixed, 1) adjustable, 2) single dependence
or 3) double dependence 1
Enter lower limit 0
Enter upper limit 1.0
Enter component to receive flux 2
Enter component to lose flux 1

Input summary for k12 (type 2)

Initial value 0.1300 float between 0.000 and 1.000

```

Transfer from 1 to 2

Enter 0 if happy with input, 1 if not, 2 to start over

### 3) *Zero order rate constant*

Zero order rate constants would normally be used to describe an infusion dose from one time interrupt value to another. A start time of 0 specifies that the infusion starts at the beginning of the simulation. A stop time of 0 represents an infusion which continues until the end of the simulation. As with the first order rate constant, components to receive and lose flux are specified. Typically, the infusion comes from a component which does not need to be modeled, thus a value of 0 (the outside world) can be used for the "from" component.

### 4-5) *Michaelis-Menten Kinetic Parameters, Vm and Km*

Rate processes can be specified as Michaelis-Menten processes, for example the rate of elimination may be as shown in the equation below.

$$\text{Rate} = \frac{V_m \bullet X(1)}{K_m + X(1)}$$

where Vm is the maximum rate and Km is the Michaelis-Menten constant. X(1) is the amount (or concentration) in the from component. The Vm and Km are entered as two separate parameters, however, the to/from information remains the same for both. Be careful of the units. If doses (and thus the values in the components of the model) are given as mg or g, then, Vm units should be mg/hr or g/hr (mass/time). Dose/initial concentrations given as mg/L will mean Vm units of mg/L/hr (mass/volume/time).

The second half of the Michaelis-Menten entry process is the Km value. Only a value need be entered, unless the parameter is adjustable or dependent. Again, be careful of units. With a dose (in g or mg) entered the units of Km should also be g or mg. However if a Cp(zero) is used with mass/volume units, Km units should be the same.

### 6) *Constant*

This is the first of the summing or intensity terms. It is necessary to distinguish between the components (and their numbers) used to describe the system of differential equations and the observed data sets (and their numbers). For example in the pharmacokinetic model above there are two components not including the 'sink'. As shown, there is one data set, Plasma. We could also specify another, second data set called Tissue, and a third called Rate of Change. When a constant is specified only the name, value and data set line is required. We might use this to offset a fixed (or adjustable) background level? Or it could be used as a constant term in a Hill equation sequence or a linear fit sequence.

### 7) *Kappa (Reciprocal volume of distribution)*

Typically, if doses are entered in mg or g, then the kappa term becomes equivalent to the reciprocal of the apparent volume of distribution (see parameter type 18). That is:

$$Cp(0) = \frac{Dose}{V(1)} = K(1) \bullet Dose$$

OR

$$Cp = \frac{X(1)}{V(1)} = K(1) \bullet X(1)$$

where X(1) is the amount in component 1 at the time specified. The units of kappa are reciprocal volume. If the dose/initial concentration is entered as an adjustable parameter the kappa term should probably be 1 and fixed.

We could also use this type of parameter with a constant term to fit a straight line. For example

$$C_{Calculated} = Constant + K(1) \bullet X_{Observed}$$

X(observed) is specified by entering 0 for the component to be added.

Specifying a negative value for the 'from' component allows the simulation of rates of change. For example, urine data may be collected (and analysed) as rate of excretion. In this case Kappa would probably be fixed with a value of 1 but with the component from specified as -x, where x is the component representing the cumulative amount in urine.

### *8-10) Sum of Exponential Terms*

Rather than specify a model in terms of components and rate constants (differential equations) it may be convenient (and generally faster) to use a sequence of exponential terms. The pre-exponential term (a) is the parameter before the exponent term. A two exponential equation could be:

$$Cp = A \bullet e^{-\alpha \bullet (X_{observed} - tlag(a))} + B \bullet e^{-\beta \bullet (X_{observed} - tlag(b))}$$

The pre-exponential terms are 'A' and 'B'. Again, the Xobserved is specified by entering 0 for component from. The lambda or exponent terms (b) in the above equation are [[alpha]] and [[beta]]. A lag time can be specified for each exponential term. Usually these lag times would be the same. Second and subsequent lag times could be made dependent on the first if adjustable.

### 11-13) *Emax (Hill Equation) Parameters*

Effect versus concentration data can modeled using this sequence of parameters. The concentration data could be entered as Xobserved values, or they could be calculated from a system of differential equations. The full equation (Hill equation) is

$$Effect = \frac{Emax \bullet X(i)^s}{Ec_{50}^s + X(i)^s}$$

where X(i) is the concentration in component 'i'. Specify component i = 0 if concentrations are entered as X-values (shown as time). Ec(50%) is the concentration which produces an effect of 50% of maximum. The third parameter is the power or slope term. You may want to try giving this a value of 1, fixed, before doing a full fit with all three parameters adjustable.

When plotting the Hill equation as Effect versus log(Concentration) it has been noticed that for the 20 - 80 % of maximum effect region a straight line may describe the Effect versus log (Concentration) well. Thus the simpler equation:

$$Effect = a \times \log_{10}(X(i)) + b$$

may be useful. Since version 2.7.9 Boomer will allow this equation by modifying the way parameter type 11 works. The third parameter, slope parameter, is used as the switch. If slope is greater than 0 the Hill equation is used in the calculation. If slope is -1 (remember to not let this parameter be adjustable) then **a** is entered instead of Emax, and **b** is entered instead of EC (50%).

For both versions of parameter type 11 a baseline 'effect' may be worth considering.

### 14) *Second order rate constant*

Second order reaction processes can be described using this parameter type. Input includes one or two components for reactants or products.

### 15-17) *Physiological Flow Parameters*

Physiologically based models can be defined by specifying blood flow rates between organs or vein/artery blood pools. A flow balance is calculated and displayed if any blood flow parameters

are specified. Generally flows in and out of an organ will need to be specified. Volume and extraction ratio data which are subsequently entered describe characteristics of the source of flow.

Drug movement from this source is calculated using the differential equation segment:

$$\frac{dX(i)}{dt} = -\frac{Q(i) \bullet X(i)}{V(i) \bullet R(i)}$$

where X(i) is the amount of drug in the source (component i), X(i)/V(i) is the concentration of drug in the source tissue or blood pool, and X(i)/(V(i)\*R(i)) is the drug concentration in the blood leaving the source tissue. In the case of vein or artery blood pool the value of R(i) should be 1. In addition to a flow term (15 above) a volume term is specified for the source organ or blood pool. Thus for blood flow from kidney to vein, the volume term would be for the kidney tissue. This volume term is used in the differential equation above and also to convert the amount values calculated internally to calculated concentration values. If you don't need to calculate values for a particular tissue you can enter 0 for the data set number. The extraction ratio, R, for the source tissue is the final term specified. For vein or artery blood pools the value of R should be 1.

### *18) Apparent volume of distribution*

Typically, if doses are entered in mg or g, the volume term can be used to relate the amount term, dose, with the concentration term measured. That is:

$$Cp(0) = \frac{Dose}{V(1)} \text{ or } Cp = \frac{X(1)}{V(1)}$$

where X(1) is the amount in component 1 at the time specified. If the dose/initial concentration is entered as an adjustable parameter the volume term should probably be 1 and fixed.

### *19) Dummy parameter for double dependence*

This parameter is not used in any calculations of y-value except for the calculation of double dependent parameters. One example might be the estimation of the bioavailability factor F. The initial amount administered may be expressed as F \* DOSE where F is unknown and to be estimate while DOSE is fixed and known. Thus F and DOSE can both be entered as dummy

parameters, one adjustable and the other fixed. The term F\*DOSE (a DOSE/Initial amount, type 1 parameter) would be specified as double dependent with double dependence type 5.

```
Enter choice for parameter 3 (-3 to 19)
  enter -3 to see choices
    enter -1 to quit this section 1
Enter parameter name F*DOSE
Enter F*DOSE value 200
0) fixed, 1) adjustable, 2) single dependence
                        or 3) double dependence 3
Two parameter dependence

1) + Par 1 + Par 2
2) + Par 1 - Par 2
3) - Par 1 + Par 2
4) - Par 1 - Par 2
5) + Par 1 x Par 2
6) - Par 1 x Par 2
7) + Par 1 / Par 2
8) - Par 1 / Par 2

0) for list of parameters

Enter choice (0-8)
```

### 20-22) SIN Function

These parameters (type 20-22) can be used to incorporate diurnal variation in a line function. Parameters include Amplitude, Period and Offset. The result of these three parameters is the addition of the value: Amplitude x SIN (2 x [[pi]] x (X - Offset)/Period) to the selected data set (line). This would result in a value varying between +/- Amplitude. Normally a constant type 6 parameter (possibly adjustable, etc) would be also be used for the same data line so that the value would vary between Constant +/- Amplitude. With both parameters defined the equation for line 1 becomes:

$$A_1 = \text{Constant} + \text{Amplitude} * \text{SIN}(2\pi * (\text{Time} - \text{Offset}) / \text{Period})$$

```
Enter choice for parameter 20
Enter parameter name Value
Enter Amplitude Value value 20
Enter data set (line) number 1
Enter line description Pressure
Enter component number (0 for obs x) 0
---
Enter Period Value value 24.0
---
Enter Offset Value value 2.0
```

### 23-24) First Order Rate Constant as a Linear Function

On occasion it may be useful to add a rate constant to a model which varies with time (or the value in a component of the model) in a linear fashion. Thus a first order rate constant can be

defined as:  $a \cdot X + b$ . The 'a' parameter is a slope term and 'b' is an intercept. The X term can be the observed x, usually time or the value (or reciprocal - entered as a negative number) in any component. Thus zero or second order rate constant can be entered with this parameter type. For example, a zero order rate constant of 5.0 could be entered as  $a(\text{SL}) = 5.0$  with drug from component 1 to 0,  $b = 0.0$  and the F-dependence equal -1, the from component. The differential equation for this process is then:

$$\frac{dX(1)}{dt} = -k \bullet X(1) \bullet \frac{1}{X(1)} = -k$$

k is now a zero order rate constant.

```
Enter choice for parameter 23
Enter parameter name k
Enter a(SL) k value 5.0
Enter component to receive flux 0
Enter component to lose flux 1
---
Enter b k value 0.0
Enter component for F-dependence (0 for obs x) -1
```

### 25-27) First Order Rate Constant as an Exponential Function

Under some circumstances the value for a rate constant may change progressively with time. For example an elimination half-life may change from 8 hours ( $k_{el} = 0.0866 \text{ hr}^{-1}$ ) to 6 hours ( $k_{el} = 0.1155 \text{ hr}^{-1}$ ) over a period of 60 hours (with a half-life of 12 hours;  $k = 0.05776 \text{ hr}^{-1}$ ) because of enzyme induction. This could be simulated with two rate constants. The first would be a type 1 parameter with a value of  $0.1155 \text{ hr}^{-1}$ . The second parameter would be type 25 with  $a = -0.0289$  ( $= -(0.1155 - 0.0866)$ ),  $b = 0.05776$ , and  $c = 0$ ). Thus the rate constant would change from  $0.0866$  to  $0.1155 \text{ hr}^{-1}$  over a period of 60 hours (5 half-lives). The differential equation would become:

$$\frac{dX(1)}{dt} = - [k + a \bullet e^{-b \bullet (time - c)}] \bullet X(1)$$

or

$$\frac{dX(1)}{dt} = - [0.1155 - 0.0281 \bullet e^{-0.05776 \bullet (time - 0)}] \bullet X(1)$$

F-dependence is also possible with this type of parameter. Specifying a positive (or negative) component for F-dependence multiplies (or divides) the above term by the amount in the specified component.

```

Enter choice for parameter 25
Enter parameter name k
Enter a(EXP) k value -0.0289
Enter component to receive flux 0
Enter component to lose flux 1
---
Enter b(EXP) k value 0.05776
Enter component for F-dependence (0 for obs x) 0
---
Enter c(EXP) k value 0

```

### 28-30) First Order Rate Constant as a SIN Function

On occasion it may be necessary to include diurnal variation in the rate constants of a model. Again by using two rate constants, one type 1 and the other type 28, it is possible to simulate or analyze this phenomenon. With just the type 28 parameter the differential equation would be:

$$\frac{X(1)}{dt} = -Amplitude \bullet SIN \left( \frac{2\pi \bullet (time - Offset)}{Period} \right) \bullet X(1)$$

F-dependence is also possible with this type of parameter. Specifying a positive (or negative) component for F-dependence multiplies (or divides) the above term by the amount in the specified component.

```

Enter choice for parameter 28
Enter parameter name k
Enter Amplitude k value 0.2
Enter component to receive flux 0
Enter component to lose flux 1
---
Enter Period k value 24.0
Enter component for F-dependence (0 for obs x) 0
---
Enter Offset k value 0

```

### 31-33) Saturable Protein Binding Elimination

Many drugs are bound to plasma protein. With large dose drugs with small apparent volumes of distribution this protein binding may be saturated. Further, for drugs which also have low extraction ratios, that is, clearance is not flow limited, elimination of **total** drug is directly related to **free** drug concentrations [Bourne, 1981; Beville, 1982]. Because of the complexity of this model its specification is relatively rigid. For example, considering i.v. bolus administration with saturable protein binding controlled elimination a dose, amount, would be added to component 1. The first-order rate constant is entered with units of reciprocal time. The association constant,  $K_a$ , has units of reciprocal concentration. The total protein,  $P_t$ , is entered as a concentration. The amount of drug is converted into total concentration with a single apparent volume of distribution (type 18) linked to the protein binding parameter, type 31, through the 'from'

specification for both parameters. If required a second data set line equal to the free drug concentration can be specified after entering the Ka value.

$$C_{Total,1} = \frac{X_{Total,1}}{V(1)}$$

$$C_{Free} = \frac{(Ka \cdot C_{Total} - 1 - Ka \cdot Pt) + \sqrt{(Ka \cdot C_{Total} - 1 - Ka \cdot Pt)^2 + 4 \cdot Ka \cdot C_{Total}}}{2 \cdot Ka}$$

$$\frac{dX_{Total,1}}{dt} = -k(PB) \cdot C_{Free,1} \cdot V(1)$$

By specifying parameter type 32, Ka and Pt parameters can be entered and thus C<sub>free</sub> versus C<sub>total</sub> data sets can be analyzed. This can be useful for the analysis of in vitro data sets.

```

Enter choice for parameter 31
Enter parameter name PB
Enter k(PB) PB value 0.2
Enter component to receive flux 0
Enter component to lose flux 1
---
Enter Ka PB value 100
Enter component for F-dependence (0 for obs x) 0
Enter data set (line) number
    for free drug concentration (0 if not required) 0
---
Enter Pt PB value 0.5

```

*34-36) First or zero order rate constants subject to inhibition*

*37-39) First or zero order rate constants subject to stimulation*

*40) Uniform [-1 to 1] Probability*

This dummy parameter can be used for single or double dependence and provides the value 0 or 1. If the parameter value (in the range -1 to 1) is greater than a random number generated uniformly distributed between -1 and 1 it provides the value 1, otherwise it provides a value of 0. One use for this parameter might be the simulation of compliance. For example, if 20% of the

doses are not taken you might use a parameter value of 0.6 (= 2 x (1 - 0.2) - 1 = 2 x (1-x) -1) where x is the 'fractional' probability for 0 or non-compliance.

#### 41) *Normal [-3 to 3] Probability*

This dummy parameter can be used for single or double dependence and provides the value 0 or 1. If the parameter value (in the range -3 to 3) is greater than a random number, normally distributed with mean 0 and standard deviation of 1, it provides the value 1, otherwise it provides a value of 0. One use for this parameter might be the simulation of compliance. For example, if 68.3% of the doses are taken you might use a parameter value of 1 (= one standard deviation above the mean), if 95.4 use a value of 2).

#### 42) *Switch parameter*

Similar to parameter type 40 or 41 except change depends on the value of a specified parameter. This parameter is set equal to 1 or 0 depending on the value of the control parameter.

#### 43) *Clone component*

Clone a component using this parameter. The new component will have the same numerical value as the 'donor' component but will not influence the donor system. Uses ??

#### 44-47) *Four parameter logistic model*

This selection allows the addition of the four parameter logistic model as describe by Kraupp et al., 1986. Normally this would be the only parameter selection for the analysis of radio-immunoassay assay data. The equation is shown below.

$$y = \frac{(A - D)}{1 + (x/C)^B} + D$$

The parameter A represents Bo, B is a shape factor, C is the midpoint of the curve (ED<sub>50</sub> and D represents non specific binding (Nsb).

#### 48-51) *Weibull function*

A four parameter Weibull function similar to Equation13 in Costa and Sousa Lobo (2001) can be fit using these parameters.

$$\text{Amount released} = Y_{\max} \bullet \left[ 1.0 - e^{-\alpha \bullet (\text{time} - T_{\text{lag}})^{\beta}} \right]$$

When amount released is expressed as a percentage Y<sub>max</sub> will be fixed equal to 100. When T<sub>lag</sub> is fixed equal to zero the two remaining parameters are alpha and beta. Alpha represents a measure of the rate of dissolution while beta is considered a shape factor.

## E. SPECIFYING PARAMETER VALUES AND LIMITS

### 0) *Fixed Parameters*

If the method selected is a simulation, then all the parameters will be fixed and you won't be asked to specify fixed, adjustable, dependent, or double dependent. Alternately if a normal or bayesian fitting is to be performed some parameters can be specified as fixed. Often dose and time interrupt values will be fixed. You may wish to hold some rate constants fixed for one run and then allow them to be adjustable in a subsequent run. Enter 0 (or press return) to specify fixed parameters.

### 1) *Adjustable parameters*

At least two adjustable parameters must be specified for a normal fitting problem. If 1 is entered to specify adjustable, a lower and upper limit are requested. The fitting process will then keep the adjustable parameter values between these limits. To reduce the influence of parameter limits you could specify a very wide range between the upper and lower limit.

### 2) *Dependent parameters*

Occasionally a parameter (value) may be used more than once in a complete model definition. If these values are adjustable it is appropriate to let the first value be adjustable but set subsequent parameters equal to the first parameter (or the negative of the first parameter). This entry is shown in the figure. Entering 0 will produce a listing of the parameters already specified.

```

Enter Choice for parameter 3 (0-14) 7
Enter parameter name 1/V
Enter 1/V value 1
0) fixed, 1) adjustable, or 2) dependent
                        or 3) double dependence 2
Enter parameter for dependence (+, 0 or -)0

# Name                Value

 1) Dose                100.0
 2) kel                 .2500

Enter parameter for dependence (+, 0 or -)1
Enter data line number Plasma
Enter component number (0 for obs x) 1

Input summary for 1/V (type 7)

Value    1.000    dependent on parameter    1
Component    1 added to line    0

Enter 0 if happy with input, 1 if not, 2 to start over

```

### 3) *Double Dependent Parameters*

Parameters can be dependent on two other parameters. This is usually accomplished using at least one dummy parameter, see above for an example.

After entering all the information required for each parameter the program will ask if you wish to make any changes. Entering 0 will bring up the list of parameter types on the screen for the next entry.

## F. EXAMPLE MODELS - BOOMER

1) *Straight Line*:  $y_{calc} = intercept + slope * x_{obs}$

Model: Std Curve = Intercept + Slope x Xvalue					
Type	Name	Value	Data Line Number or Component To	Line Name	Component From
6	Intercept	10	1	Std Curve	
7	Slope	1.5	1		0

2) *Sum of exponentials*  $C_p = A * e^{-\alpha * (t-tlag)} + B * e^{-\beta * (t-tlag)}$

Model: $C_p = A * e^{-\alpha * t} + B * e^{-\beta * t}$					
Type	Name	Value	Data Line Number or Component To	Line Name	Component From
8	A	25	1	Cp	0 <sup>1</sup>
9		1.5			
10		0.5			
8	B	15	1	2	0
9		0.23			
10		0.5			

1	Use Xobs (i.e. Time) no differential equation
2	Same line so name is not required

3) *Two compartment pharmacokinetic model, with infusion dose*

Model: Two Compartment Pharmacokinetic Model with Infusion Dose							
Type	Name	Value	Start Time	Stop Time	Data Line Number or Component To	Line Name	Component From
2	k10	0.25			0 <sup>1</sup>		1
2	k12	1.5			2		1
2	k21	2.3			1		2
18	V1	5			1	Cp	1
0 <sup>2</sup>	Stop Time	0.5					
3	Infusion Rate	20	0 <sup>3</sup>	1 <sup>4</sup>	1		0

<p>1 Outside world or sink</p> <p>2 Specify Time Independent Variables (k's and V) first</p> <p>3 Start at Time Zero</p> <p>4 Stop at Time #1 (i.e. 0.5)</p>
--

The above examples indicate the entries required to define the models specified. If the run is for a fit to data, additional information as described in the 'Specifying Parameter Values and Limits' would be necessary.

-----

Typically the user is simply asked to select the required model. In the subroutine model parameters such as number of lines (ln), differential equations (ndeq), parameters (m), and constants (nc) are defined as well as names for the model (modst), parameters (ps), and constants (cst).

## H. NUMERICAL INTEGRATION METHOD

If the number of differential equations in the model is greater than zero, then the next question is choice of numerical integration method.

## Method of Numerical Integration

- 0) Classical 4th order Runge-Kutta
- 1) Runge-Kutta-Gill
- 2) Fehlberg RKF45
- 3) Adams Predictor-Corrector with DIFSUB
- 4) Gears method for stiff equations with PEDERV
- 5) Gears method without PEDERV

Enter choice (0-5)

### *1. Classical 4th order Runge-Kutta*

This is a relatively slow method but reasonably robust. The relative error is controlled by decreasing the step size and reevaluation.

### *2. Runge-Kutta-Gill*

This is another fourth order method. Again it is slow, and the relative error is controlled by adjustment of step-size. This is the method used in MULTI(RUNGE) but with automatic control of step size added in Multi-Forte and included in Boomer.

### *3. Fehlberg RKF45*

This method involves a fourth order evaluation with a fifth order used for efficient selection of optimal step-size. It is quite efficient and requires relative and absolute error values.

### *4. Adam Predictor-Corrector*

This method is incorporated into the DIFSUB subroutine and can be used for non-stiff systems of differential equations. The overhead involved in this subroutine makes it less efficient for small systems of differential equations. Possibly it would be better with bigger systems. An absolute error term is requested for error control.

### *5. Gear with S/R Pederv*

The Gear method is a very good method for solving systems of stiff equations. Again an absolute error value is required. Also with this option a subroutine PART must be described by the user for use by the subroutine PEDERV. The partial derivative of each equation with respect to each dependent variable is entered in subroutine PART. Thus if there are n differential equations and therefore n dependent variables, there will be n\*n terms defined in PART. Commonly many of these terms will be zero, but they must all be defined.

### *6. Gear without Pederv*

This is also a good method for solving stiff equations. The subroutine PART is not required for this method as the partial derivatives are determined by numerical differencing. An absolute error term is also used in the step-size control process. This method may be slower than method 4 (with Pederv) but the PART subroutine is not required. Boomer automatically includes the PART subroutine so either method can be used.

## I. NUMERICAL INTEGRATION - ERROR TERMS

Relative and/or absolute error values are requested if numerical integration is required. Since all calculations are performed in single precision (in this version) specifying a relative error of less than 0.00001 may cause problems. For the same sort of reason very small values for the absolute error are not recommended and may in fact cause a failure of the program. The default value for each parameter is 0.0001 which can be entered by pressing return. Larger values for the error term should also be avoided especially if the program is used to fit to a data set. With a tight convergence criteria (low PC value, see below) and a larger error term the iteration process may oscillate erratically. This can be readily induced using a non-stiff system of differential equations and Gears method of numerical integration for a fitting problem. A large absolute error term and low PC value also helps.

```
Enter Relative error term for  
Numerical integration (0.0001)
```

```
Enter Absolute error term for  
Numerical integration (0.0001)
```

### FITTING METHODS

```
0) Gauss-Newton  
1) Damping Gauss-Newton  
2) Marquardt  
3) Simplex  
4) Simplex->Damping GN
```

```
Enter Choice (0-4) 4
```

## J. FITTING ALGORITHM

Unless the simulation method of analysis is chosen, the next request is for the specification of the fitting algorithm. These algorithms are as presented in the original MULTI programs, simply translated to FORTRAN.

### 1. *Gauss-Newton*

This is generally the fastest method, but it may diverge giving much slower times, or get lost giving incorrect answers. With good initial estimates for the parameters this can be a very useful method.

### 2. *Damping Gauss-Newton*

This is also a quick method with the tendency to diverge more or less under control. It may still get lost if given poor initial estimates. Rerunning the same analysis with different initial estimates can give more confidence in a consistently achieved minimum sum of squares. This method would generally be the method of choice.

### 3. *Marquardt*

In this method the Gauss-Newton approach has been altered to give better performance for oddly shaped sums of squares surfaces. For most problems it is slower than options 0 or 1.

#### 4. *Simplex*

This method can be quite slow, although not too bad. It can be especially useful in a case with poorer initial estimates. It is supposed to be more robust. Better data and/or better initial estimates will also help. This method will occasionally fail to produce a best fit. As the initial simplex is produced randomly rerunning the analysis with the same initial estimates will produce a different analysis, with possibly the same end-point.

#### 5. *Simplex -> Damping G-N*

With this analysis the simplex method is used at first because of its robustness. The final results from the simplex method are then used with the damping Gauss-Newton method for further refinement of the analysis.

#### *One parameter method*

When only one adjustable parameter is specified another fitting method is automatically selected. This method is essentially a damped Newton-Raphson method.

### K. FITTING CRITERIA

#### 1. *DT value*

If a fitting method (i.e. not a simulation) other than the simplex method is chosen the program will request a value for DT. Entering 0.0 (or pressing return without an entry) will cause the default value of 0.001 to be used. The DT value is used in the calculation of the partial derivatives of the WSS with respect to the parameter values. This value is used as a fractional change in the parameter value during the calculation of the partial. (If the parameter value is zero, the DT value is used as an absolute change in value). Too large a number may lead to a distorted search for the minimum WSS, too small a value may over emphasize rounding errors.

#### 2. *PC value*

If a fitting method is chosen (i.e. not a simulation) a value for PC will be requested. For the Gauss-Newton/Marquardt methods a default value of 0.00001 is suggested, whereas for the simplex method the default value is 0.0001. The PC value for the Gauss-Newton methods controls the convergence exit during the iteration process. If the relative change in the WSS is smaller than PC the iteration process is terminated normally. For the simplex method the convergence criteria is based on the relative change in the parameter values compared with the value of PC.

### L. DATA SET TITLE

This is used to identify the data set. Up to 60 characters can be entered. The data set title is printed with the final output.

### M. INDIVIDUAL DATA VALUE ENTRY

Enter data from

0) Disk file            2) ...including weights

- 1) Keyboard                    3) ...including weights

### 0) *Disk File*

If the data has been previously entered and stored in a data file it may be read by the program. This request is followed by a request for the .DAT filename. Again the .DAT part of the name should not be entered.

The data file format has changed from previous versions of MultiForte and Boomer. Data files now consist of two column data with a tab character between the 'x' and the 'y' value (and 'weight' if appropriate). A carriage return separates each data pair. This format is consistent with spreadsheet and graphing program formats. The current versions of Boomer will automatically read data in the older Boomer and MultiForte formats.

### 1) *Keyboard*

With this option the individual time/concentration data are to be entered from the keyboard. Entering -1 for time will end this data entry.

### 2) *and 3)*

are the same except the user enter estimates of the weight to be applied to each data point. This should usually be the reciprocal of the variance of the data point.

After data entry from the keyboard, or by choice after reading the data from a disk file, the data set may be viewed or edited. Editing is quite complete with options to change, delete, insert an individual data point or add an offset to the x-values of the data line. After data entry or editing the data set can be saved as a .DAT file by specifying the disk file name. Again reusing a file name will result in the loss of the older data.

## N. WEIGHTING SCHEME

If no weight is entered during the data entry process the program will ask for the user to select from various formulas. The relative error in each data point may or may not be known. The user may have some information about the relative error in each measurement. This may be independent of the value or proportional to some function of the value. The fitting process can be made aware of this information by use of a weighting scheme. Boomer allows a number of different weighting schemes to be used, including specifying the weight for each data point using option 2 or 3 in the previous section.

Weighting function entry for [Drug]

- 0) Equal weights
- 1) Weight by  $1/C_p(i)$
- 2) Weight by  $1/C_p(i)^2$
- 3) Weight by  $1/a * C_p(i)^b$
- 4) Weight by  $1/(a + b * C_p(i)^c)$
- 5) Weight by  $1/((a+b * C_p(i)^c) * d^{(t_n-t_i)})$

### 0) *Equal weight*

An unweighted least squares fit can be specified by giving each data point an equal weight.

1) *Weight by  $1/Cp(Obs)$  or  $1/Cp(Calc)$*

Each data point can be weighted by the reciprocal of the observed or calculated data value. This may be a reasonable alternative to the unweighted least squares.

2) *Weight by  $1/Cp(Obs)^2$  or  $1/Cp(Calc)^2$*

The square of the observed or calculated value is used in the weighting calculation.

3) *Weight by  $1/(a * Cp(Obs)^b)$  or  $1/(a * Cp(Calc)^b)$*

This option allows non-integer powers of the observed or calculated concentration to be used in the weighting process. The values of a and b could be determined from the data by plotting log(average concentration) versus log(variance) from multiple subject data sets as proposed by Wagner [[Wagner, 1975](#)].

4) *Weight by  $1/(a + b * Cp(Obs)^c)$  or  $1/(a + b * Cp(Calc)^c)$*

This is an even more flexible version of the above scheme.

5) *Weight by  $1/((a + b * Cp(Obs)^c) * d^{(tlast - ti)})$  or  $1/((a + b * Cp(Calc)^c) * d^{(tlast - ti)})$*

This allows incorporation of estimated assay sensitivity (a may equal sensitivity<sup>2</sup>) and coefficient of variation (b may equal CV<sup>2</sup>) as well as reducing emphasis on older samples (d, typically 1.01 to 1.05) as may be appropriate in a clinical setting. This type of weighting scheme has been incorporated into some clinically useful Bayesian estimation programs [[Peck, 1984](#)].

For simulations a weight of 1 is arbitrarily assigned to each data point. Observations with a value of zero are given a weight of zero. Selection of a 'best' weighting scheme is aided by consideration of the weighted residual plots which can be printed by Boomer.

## O. ENTRY OF INITIAL PARAMETER ESTIMATES

### 1. *Parameter values*

With all analyses (except simulations with no parameters) initial values for each parameter are required. Generally the better the estimate the better the analysis.

### 2. *Parameter limits*

For all analyses (except for simulations) parameter limits, upper and lower, are requested. These limits can be wide or very close, it's up to the user. For those preferring no limits, very wide limits will suffice. These values are not used in anyway to change the parameter domain, but simply act as absolute limits for the parameter values. More like a box than a curved dish. When limits are specified some care may be necessary. For example, a lower limit for a volume of distribution value entered as zero may cause problems if the limit is approached during the early part of an iterative run. A value for volume of zero will give infinite calculated plasma concentrations and can cause an early exit to the fitting. A lower limit of zero for rate constants is usually better tolerated.

### 3. Population values

If the Bayesian estimation procedure is chosen then the user must supply estimates of the population mean parameter value. Also required is an estimate of the uncertainty in the population value. This is entered as the population standard deviation. If a larger uncertainty is to be used a larger value for the population standard deviation would be entered.

## P. SIMULATION WITH ERROR INPUT

Simulation with random ERROR

- 0) no error for line ( 1)
- 1) error = uniform error
- 2) error = normal error
- 3) error = uniform error x true value
- 4) error = normal error x true value
- 5) error = log normal error about true value
- 6) error = EXP(normal error)

Enter choice (0-6) 6

Enter error intensity factor

If a simulation is chosen, parameter limits etc are not required. When simulation with error is specified information about the type and magnitude of the error is requested. Uniform, normally distributed, log normal and exponentially distributed error can be specified. This error may be simply added to the calculated value (choices 1 and 2) or multiplied by and added to the calculated value (choices 3 and 4). The intensity factor refers to the magnitude of the error. With choices 1 and 2 this would be the maximum error or the standard deviation of the error added. For choices 3, 4, and 6 this is a fractional values. For example, a value of 0.1 with choice 3 would mean that the added error would have a standard deviation of 10% about the calculated value.

- 1)  $Val_n = Val_o + Uni \times Int$
- 2)  $Val_n = Val_o + Nor \times Int$
- 3)  $Val_n = Val_o \times (1.0 + Uni \times Int)$
- 4)  $Val_n = Val_o \times (1.0 + Nor \times Int)$
- 5)  $Val_n = 10 \log(Val_o) + Nor \times Int$
- 6)  $Val_n = Val_o \times e(Nor \times Int)$

where

$Val_n$  = new value

$Val_o$  = original value

Int = intensity factor (standard deviation)

Uni = uniformly distributed random number between -1 and + 1

Nor = normally distributed random number with mean zero and standard deviation equal to the intensity value

Log = log normally distributed random number

Exp = exponentially distributed random number

## Q. AUC, AUMC, AND MRT

The program will automatically calculate the area under the curve (AUC), the area under the first moment curve (AUMC), and the mean residence time (MRT) of any data set. For accurate numbers a zero (dummy or otherwise) data point is needed. The program uses the trapezoidal rule to calculate the areas. The program uses the last two **calculated** data points to calculate a terminal slope for extrapolation to zero. Calculated zero time values are used if an observed zero time value is zero. If no zero time value is given a warning is issued. Zero time values with zero value are given zero weight in any fitting analysis. Enter 0 to exit this section.

## R. ADDITIONAL OUTPUT INCLUDING SAVING DATA, GRAPHS, EXTRA FILES AND SENSITIVITY OUTPUT

### Additional Output

Enter ->	0	1	2	3	4	5	6	7	8	9	10	11	12	13	14	15
Save Data		x		x		x		x		x		x		x		x
Graphs			x	x			x	x			x	x			x	x
Extra files					x	x	x	x					x	x	x	x
Sensitivity									x	x	x	x	x	x	x	x

Save calculated data files, Produce linear, semi-log and weighted residual plots, save extra data files or perform sensitivity or optimal sampling analysis

Enter choice (0-15)

Enter 0 - Continue without additional output

This leads to the next analysis without any plotting.

Enter 1, 3, 5, 7, 9, 11, 13, or 15 - Save data on disk for later graphing

Select FORMAT for x-value

- 0) Don't save data
- |           |           |
|-----------|-----------|
| 1) G14.1  | 2) G14.2  |
| 3) G14.3  | 4) G14.4  |
| 5) G14.5  | 6) G14.6  |
| 7) F14.0  | 8) F14.1  |
| 9) F14.2  | 10) F14.3 |
| 11) F14.4 | 12) F14.5 |
| 13) F14.6 |           |

Enter choice (0-13)

This option allows writing the calculated values and/or the standardized residuals to disk files (.DAT files) for later analysis. Suitable file name(s) are requested as before. These data files are output as x-value, tab, y-value, return. Via the clipboard, this format should be compatible with a variety of Macintosh programs. Many programs will read the .DAT files directly. The data format can be specified in the dialog box. Choices include a 'G' general format with 1 through 6 digits or a 'F' floating point format with 0 through 6 decimal places. [Overflow with the 'F' format will produce 14 \*s]. The file name (without extension) should also be provided.

Enter 2, 3, 6, 7, 10, 11, 14, or 15 - Produce a printer plot now

Printer-type plots (not high resolution) can be prepared for quick evaluation of the fit to the data. Four types of plots are produced. Linear and semi-log observed versus time, standardized residual versus time and standardized residual versus observed y value. These plots can be useful in the evaluation of the model or the selected weighting scheme [[Draper, 1966](#)].

When there is more than one line of data the program also prints a combined plot for standardized residuals versus time or observed y value.

Example Plot Output

Plots of observed (\*) and calculated values (+)  
versus time for Cp . Superimposed points (X)

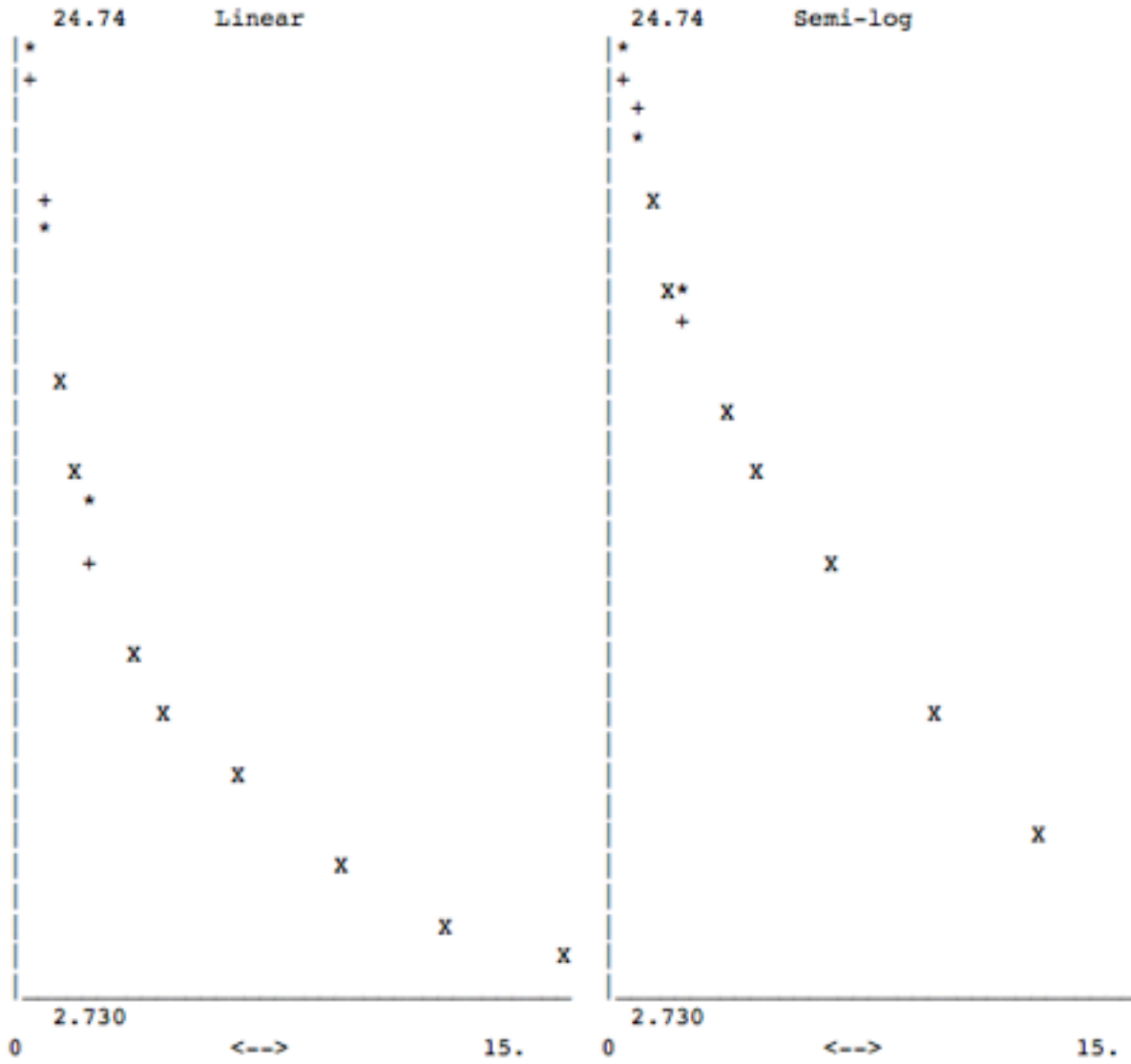

Example Standardized Weighted Residual Plot

Plot of Std Wtd Residuals (X) versus time for Heart\_Rate

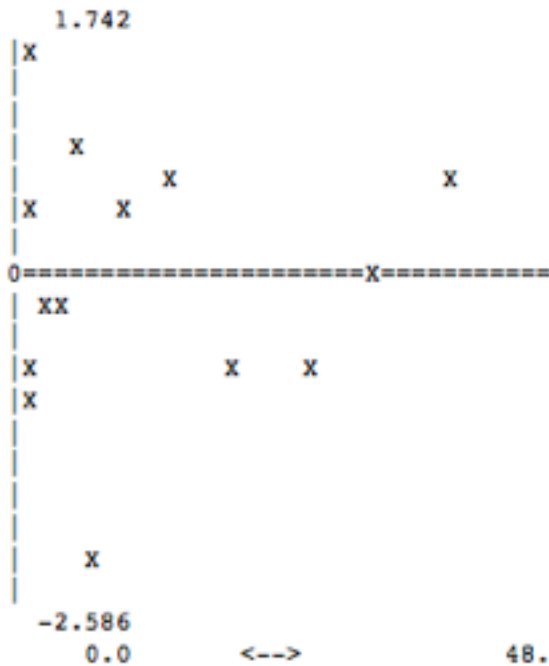

Plot of Std Wtd Residuals (X) versus log(calc Cp(i)) for Heart\_Rate

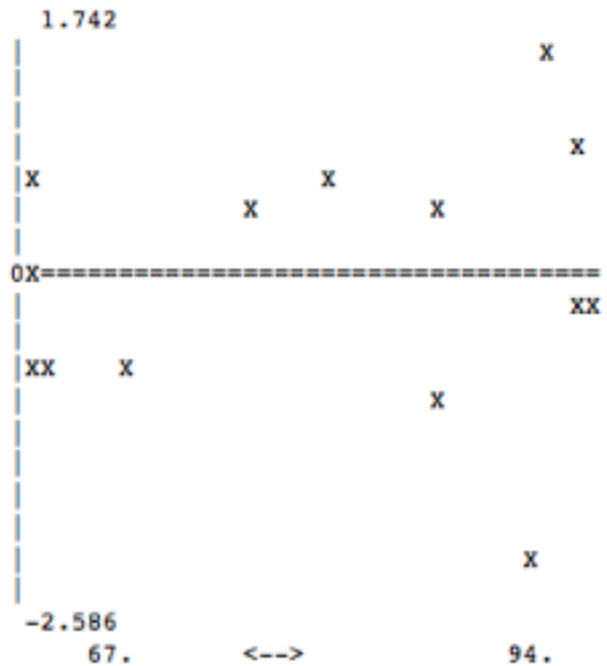

Enter 4, 5, 6, 7, 12, 13, 14, or 15 - Extra output files

Choosing this option produces extra output files. **\*\*\*.htm**, **\*\*\*.csv** and **\*\*\*.mdl** files. The htm file is a html formatted file for web display or input as external data by OpenOffice. The csv file can be read by a spreadsheet program such as Excel or OpenOffice. The mdl file contains details of the model with parameter values. The mdl file may be used as is for input [or edited](#).

Enter 8, 9, 10, 11, 12, 13, 14, or 15 - Sensitivity or Optimal Sampling Output

With this option the program break the x scale (time) into 100 segments and calculate the sensitivity value according to the formula.

$$\left[ \frac{100 \bullet (Cp_{Pi \bullet 1.005} - Cp_{Pi \bullet 0.995})}{Pi} \right] \bullet \sqrt{wt}$$

These values are graphed versus the x value and the maximum value is output as well.

```

For kel
  Max for line (A) Cp           is  494.3      at  48.00
  Max for line (B) Heart_Rate  is  55.58      at  13.44

```

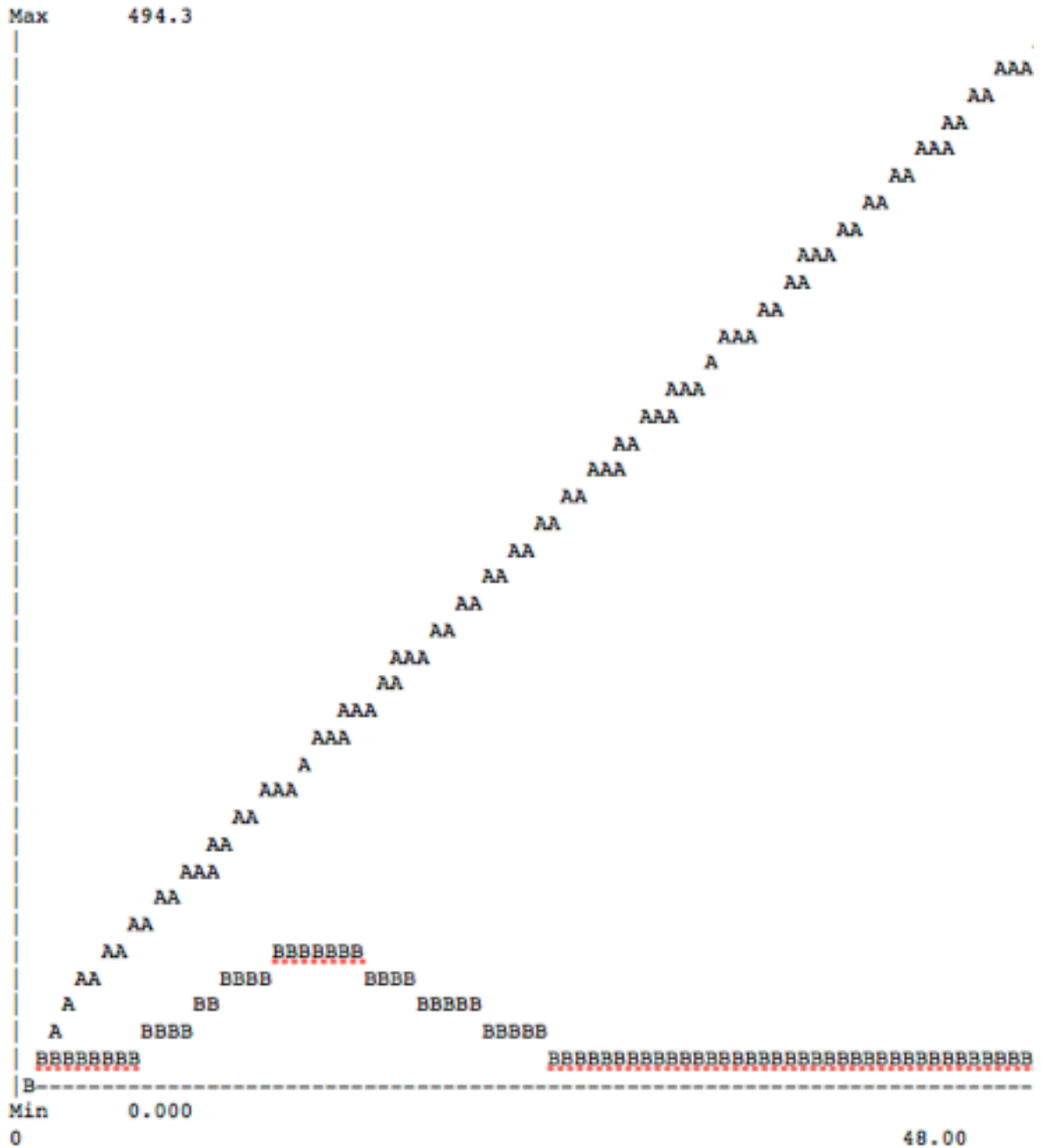

The weight scheme for these data were:

```

Weighting for Cp           by 1/a*Cp(Obs )^b
  With a = 0.2500E-02 and b = 2.000
Weighting for Heart_Rate   by 1/a*Cp(Obs )^b
  With a = 4.000      and b = 0.000

```

## Three Dimensional WSS Output Table

If the grid search method is chosen the program may output the WSS at each point on the specified grid with the parameter values to two disk files per pair of parameters. One disk file is in SYLK format for entry into the DeltaGraph(c) graphing program. The other file is in tab-return delimited format for entry into spreadsheets etc. With this output WSS surface plots can be generated.

## S. NOTES

### *1. Batch Files*

Creating a batch file on the run could be useful if you have a large number of data sets requiring similar analyses. Alternately, a single data set may be analyzed by different weighting schemes. You could enter the first set of information from the keyboard, creating a batch file as you go. The batch file could then be edited and the section containing data repeatedly duplicated using the copy and paste commands. An entry of -1 is used to terminate the data entry. This will need to be changed to 0 at the end of each set except the last. (This final -1 must be followed by a carriage return or it will not be properly recognized.) When editing the batch file, be sure to change data file names and initial estimates for parameter values. Do not change the integer or real number description starting in column 40.

## References

Kraupp, M., Marz, R., Legenstein, E., Knerer and Szekeres, T. 1986 Evaluation of Radioimmunoassay Calculations by Four Parameter Logistic and Spline functions, *J. Clin. Chem. Clin. biochem.*, **24**, 1023-1028

Costa, P., and Sousa Lobo, J.M. 2001 Modeling and comparison of dissolution profiles. *Eur. J. Pharm. Sci.* **13** (2) 123-33

## Chapter 5

# 5. Output Information

Boomer can output the final results to the terminal screen or a disk file (.OUT file). Intermediate results may also be output to the terminal screen. [Be careful, command-C or command-. will cause an exit from the program]. The output is headed by the version number and the system date and time. The title, fitting algorithm, weighting information, DT (if appropriate), PC, number of iteration loops, and damping (if appropriate) are printed next. For simulations, the elapsed time is displayed for comparison purposes.

The next section displays the final parameter values. The number, name, final fitted value, standard deviation (SD), percent coefficient of variation (CV), inputted lower limit and upper limit are displayed for each parameter. A warning is given if any of the parameter values are within 5% of the upper or lower limit.. A coefficient of variation of greater than 50% can indicate that the model selected has too many parameters, or that the data are insufficient or too 'noisy'. The SD or CV information is more an indication of how good the fit is or how noisy the data appears and does not give much information about the population statistics of the parameters.

If a Bayesian analysis was selected the population mean and standard deviation inputted, the square root of the weight for the parameter (1/standard deviation), and the weighted residual are printed. The weighted residual is calculated as (parameter value-population mean value) times the square root of the weight. Thus the weighted residual squared is the contribution of this parameter to the overall WSS.

The model fit can be evaluated in part by looking at the next output. The sum of the weighted squared residuals (WSS), the unweighted coefficient of determination ( $R^2$ ), and the unweighted correlation coefficient (R) between the observed and calculated y-values. The mean error (ME), mean absolute error (MAE) and root mean squared error (RMSE) are useful parameters for determining how useful the model might be at predicting future results. Akaike's information criterion (AIC), Schwarz criteria (SC), and log likelihood (LL) are useful criteria for determining which model is best (Note always use the same weighting scheme when making this determination.

$$AIC = N \cdot \ln (WSS) + 2 \cdot M$$

$$SC = N \cdot \ln (WSS) + M \cdot \ln(N)$$

$$LL = -N/2 \cdot [\ln (2 \cdot \pi) + \ln (WSS/N) + 1] \text{ (from xycoon.com)}$$

where N = number of data points (weighted); WSS = the weighted sum of squares; and M = the number of adjustable parameters.

The lowest value of AIC, SC, the smallest value of WSS, and the value of R<sup>2</sup> closest to 1.000 indicate a best fit [[Akaike, 1973](#); [Yamaoka, 1978](#)]. The AIC value can be quite useful in evaluating the number of terms in a given model type (e.g. two or three exponentials, 4 or 6 parameters). If the same weighting scheme is used the model with the lower AIC value is generally the more significant. This result can also be determined by comparison of the F value obtained by comparing the two models [[Mandel, 1964](#); [Boxenbaum, 1974](#)];

$$F(df_j - df_k, df_k) = \frac{WSS_j - WSS_k}{WSS_k} \times \frac{df_k}{df_j - df_k}$$

where WSS<sub>j</sub> is the sum of the weighted squared residuals obtained with the jth set of parameters. For example, j may refer to the one compartment model and the k to the two compartment fit.

In Boomer, the Model and Parameter Definition section is next. In this section all the constants and parameters are displayed with name, value, type, from, to, dep, start, and stop information in a compact tabular form. Careful analysis of this section should help to ensure that the model has been entered correctly. This is followed by information about the fitted data. Data for each line is presented as data number, time (x or independent value), calculated and observed concentration (y or dependent value), (weight), and weighted residual. The weight value is actually the square root of the weight used for each data point during the final calculation. The weighted residual is calculated as (observed value - calculated value) times the square root of the weight. Squaring and summing these values will give the WSS for this data set. At the end of each data set or line the calculated WSS, weighted R<sup>2</sup>, and unweighted R value are printed. This allows the analyst to determine which line is contributing most to the overall WSS in multi-line data sets. In the case of Bayesian analysis it allows the analyst to see the contribution of the concentration data and contrast this with the contribution of the fitted parameter values.

Post fitting information generated in the S/R MODELOUT will be printed at this point. In the demo model set, the AUC is calculated for data fit by models 1-4,13-16. Additional information is output for the two compartment - I.V. bolus model (#13). This includes calculated values for k<sub>10</sub>, k<sub>12</sub>, k<sub>21</sub>, V<sub>1</sub>, V<sub>beta</sub>, V<sub>ss</sub>, and total body clearance. The details of these calculations can be seen in the source code for this subroutine in the MODEL.DEMO text file. Boomer will calculate AUC, AUMC, and MRT information for each data set line.

Data can be optionally output in printer plots. These plots include linear and semi-log plots of observed and calculated y values *versus* x values, standardized weighted residuals versus x, and standardized weighted residuals versus calculated y values. The standardized weighted residuals are calculated as (observed y value - calculated y value) times the square root of the weight divided by the standard error. The standard error is calculated as the square root of WSS divided by the number of data points minus the number of parameters (or divided by just the number of

point with a Bayesian analysis). The first two plots give the analyst a general 'feel' for the fit. Outliers may become obvious, systematic deviation between the observed and calculated data points may be obvious. The two residual plot can be very useful in the evaluation of the weighting scheme selected or the model selected. Non-random residuals may well mean a poor weighting scheme or a model with insufficient parameters (Draper and Smith 1966) [[Draper, 1966](#)].

Again, all of the above output can be directed to a disk file for inclusion, as a text file, into a report etc. Calculated values versus time or the standardized residuals versus time data can be saved as disk files for later enhancement with a plotting program such as DeltaGraph Pro (Mac graphing program). The data is saved as a text file with x and y values separated by a tab and each data pair separated with a carriage return.

# 6. Boomer Tutorial

## A. NORMAL FITTING - TWO COMPARTMENT I.V. BOLUS MODEL

Dose: 250 mg I.V. Bolus	
Time hr	Concentration mg/L
0.25	10.8
0.5	8.5
1	6.2
2	4.9
3	4.4
4	4.0
6	3.4
12	2.0

After a 250 mg iv bolus administration the data below were collected.

Plotting the data on semi-log graph paper gives the 'X' below.

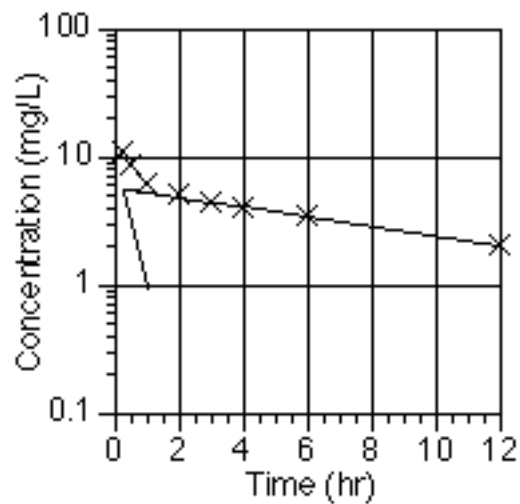

Semi-log linear regression of the last five data points gives;  $B = 5.8 \text{ mg/L}$  and  $\beta = 0.089 \text{ hr}^{-1}$ . The residual line results in;  $A = 9.3 \text{ mg/L}$  and  $\alpha = 2.3 \text{ hr}^{-1}$ . Manipulation of these results gives the values;  $k_{21} = 0.938 \text{ hr}^{-1}$ ,  $k_{10} = 0.218 \text{ hr}^{-1}$ ,  $k_{12} = 1.233 \text{ hr}^{-1}$ , and  $V_1 = 16.6\text{L}$ . The next step is to define the model on paper. This is shown at the right.

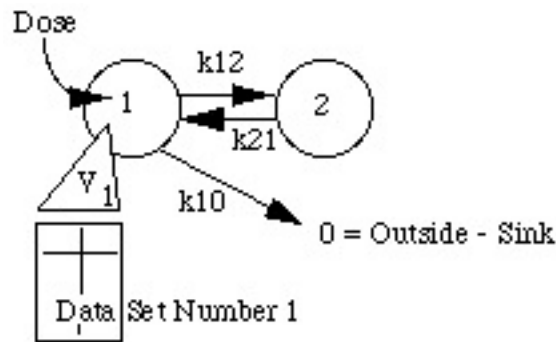

Number each component (circles) of the model in sequence. The central compartment is represented by component 1. The tissue compartment is component 2. There is one data set or data line. This is Data Set Number 1. The model is further defined by three first order rate constants (arrows) and one apparent volume of distribution (triangle). The apparent volume of distribution relates the amount of drug in the central compartment to the plasma concentrations in the data set. Including the dose there are five parameters needed to fully define the model. These are summarized in the table, below.

Parameters for I.V. Bolus - Two Compartment Model								
Type	Name	Value	Fixed, Adjust...	Lower Limit	Upper Limit	To	Line Name	From
1	Dose	250	0			1		
2	k10	0.218	1	0	1	0 <sup>1</sup>		1
2	k12	1.253	1	0	10	2		1
2	k21	0.938	1	0	10	1		2
18	V <sub>1</sub>	16.6	1	1 <sup>2</sup>	100	1	Cp	1

1 Component '0' is the outside or sink  
 2 Lower limit for V must be greater than zero

Start Boomer and select Keyboard entry. Select normal fitting (0), screen output (0) and proceed to parameter definition and entry. Enter each of the parameters from the table below. Enter -1 for parameter type to complete this section. Choose Runge-Kutta-Fehlberg (2) as the numerical integration technique and press return twice to accept the default values for relative and absolute error. Choose Damping Gauss-Newton (1) as the fitting algorithm and again press return twice to accept the default values of DT and PC. Enter a title for this run 'Two compartment Fit to Data' and select keyboard data entry. Enter the x-value and y-value data. Enter -1 for x-value to finish the data entry. Press return (for 0), unless you need to correct some of the data points. Press return if you don't want to save the data. If you want to save the data enter a file name and choose the required format for the x and y-values.

The available formats are G14.1 to G14.6 and F14.0 to F14.6. All of these formats produce data within 14 columns. The G format changes from fixed format to scientific format as necessary and is better if a wider range of values are expected. The number after the decimal point indicates the number of digits saved. The F format is fixed format with the number after the decimal point indicating the number of digits after the decimal point in the number. Examples include

<b>G14.2</b>	<b>12.</b>	<b>1.2</b>	<b>.12E+10</b>	<b>.12E-04</b>
<b>G14.4</b>	<b>1234.</b>	<b>12.34</b>	<b>.1234E+10</b>	<b>.1234E-05</b>
<b>G14.6</b>	<b>123456.</b>	<b>12.3456</b>	<b>.123456E+10</b>	<b>.123456E-06</b>
<b>F14.0</b>	<b>12.</b>	<b>1.</b>	<b>0.</b>	
<b>F14.2</b>	<b>12.34</b>	<b>1.234</b>	<b>.12</b>	
<b>F14.4</b>	<b>12.3456</b>	<b>1.2345</b>	<b>.1234</b>	
<b>F14.6</b>	<b>12.345678</b>	<b>1.234567</b>	<b>.123456</b>	<b>*****.*****</b>

The last entry indicates any number greater than 9999999.999999 in F14.6 format.

A variety of data weighting schemes is possible. Enter 0 to select equal weights. The program will now undertake the data analysis and finally produce the output information. This includes the model specification, final parameter values and calculated data. Choose 0 for AUC line and enter 2 to produce a linear and semi-log plot of the observed and calculated data, and weighted residual plots. This completes the analysis.

A list of the keyboard entries required for this analysis are included in the file Tutorial\_1a.BAT. You may want to either open the file in the editor or print it out for reference. It is also possible to run this analysis by starting Boomer, selecting Batch File run and enter Tutorial\_1a as the filename.

An alternative approach to the analysis of these data is to fit the data with a sum of exponential equation such as:

$$C_p = A * e^{-\alpha * t} + B * e^{-\beta * t}$$

This is carried out in the same way as the first example except for the model definition and the lack of numerical integration routine (and error terms) specification.

Parameters for I.V. Bolus - Sum of Exponential Terms								
Type	Name	Value	Fixed, Adjust...	Lower Limit	Upper Limit	To	Line Name	From
8	A	9.3	1	0	25	1	Cp	0 <sup>1</sup>
2		2.3	1	0	10			
		0.0	0					
8	B	5.8	1	0	10	1	3	0
		0.089	1	0	1			
		0.0	0					

1 Enter 0 for 'from' to use observed x-value  
 2 No entry required since types 9 and 10 are assumed  
 3 No entry required since already specified for A

## B. BAYESIAN ANALYSIS - I.V. INFUSION WITH KEL FUNCTION OF CREATININE CLEARANCE

This example set involves the analysis of plasma concentrations measured after an i.v. infusion of 200 mg/hr for 30 minutes to a patient with a creatinine clearance of 30 ml/min. The measured concentrations were:

Plasma concentration 1 hour after the start of the infusion = 4.0 mg/L  
 Plasma concentration 12 hours after the start of the infusion = 1.7 mg/L

From previous experiments with this drug in similar patients it has been found that:

$$k_{el} = a * CL(Cr) + b$$

where a = 0.0028 +/- 0.00028  
 b = 0.02 +/- 0.002

and

$$V(1) = 21 \pm 2.1 \text{ L}$$

We can set up the model first on paper.

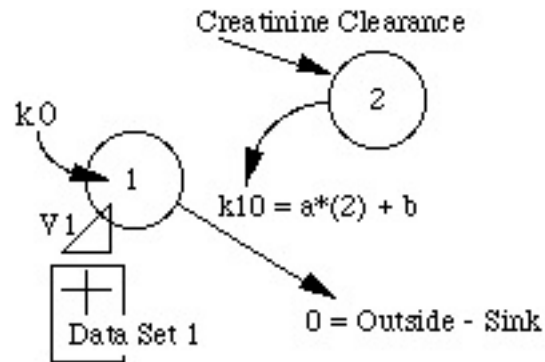

Component 1 represents the one compartment model with a first order elimination rate constant  $k_{10}$ . Linking the amount of drug in component 1 with the concentration in data set 1 is the apparent volume of distribution,  $V_1$ . By putting the value of creatinine clearance in component 2 without any rate constants (it will stay fixed) we can now calculate  $k_{10}$  as a function of creatinine clearance (using parameter type 23).

Start Boomer and select Keyboard entry. Select Bayesian fitting (1), screen output (0) and proceed to parameter definition and entry. Enter each of the parameters from the table below.

Parameters for I.V. Infusion - Bayesian Analysis						
Type	1	23		18	0 <sup>1</sup>	3
Name	CrCL	k10		Y1	Duration	k0
Value	30	.0028 <sup>2</sup>	.02 <sup>3</sup>	21	.05	200
Start						0
Stop						1 <sup>5</sup>
Fixed, Adjust...	0	1	1	1	0	0
Lower Limit		0	0	1 <sup>4</sup>		
Upper Limit		0.01	0.1	100		
Mean		0.0028	0.02	21		
Std Dev		0.00028	0.002	2.1		
To	2	0		1		
Data Set Name				Cp		
From		1	2	1		0

1	Define type 0 parameters after all the time independent definitions
2	Slope
3	Intercept
4	Lower limit not equal to zero
5	Stop infusion at time = First type 1 parameter = Duration

After entering all the parameters enter -1. Choose integration method 2 and choose the default for the relative and absolute error terms by pressing return. Use the Marquardt fitting algorithm and the default DT and PC values. After entering the title for this analysis choose data from keyboard (1). Enter time and Cp values of 1 hr, 4 mg/L and 12 hr, 1.7 mg/L, respectively. Accept the data 'as is' unless you need to make a correction. Continue without saving the data. With a Bayesian analysis a little more attention needs to be taken regarding the weighting of the data. When the parameters were entered a standard deviation value for each parameter is entered and then used as a weighting factor during the fitting process. We must also use a

'suitable' weighting scheme for the plasma data. One scheme might be to assume that the standard deviation for each data point is 10% of the data value. Thus

$$\text{Standard Deviation} = 0.1 \times \text{Value}$$

or

$$\text{Variance} = 0.01 \times \text{Value}^2$$

And if the weight is to be  $1/\text{Variance}$  a weighting scheme type 3 may be most useful where

$$\text{Weight} = 1/(a \times \text{Value}^2) \text{ with } a = 0.01 \text{ and } b = 2.$$

A batch file, Tutorial\_2.BAT, includes all the commands for this analysis.

### C. WORKING WITH BATCH (.BAT) FILES - SIMULATION

In the two previous tutorials all the program entries were made from the keyboard. There are two other possibilities when working with Boomer. A batch file can be created while you are entering the instructions from the keyboard or a batch file can be used as the source of all the instructions. Once a batch file is created it is possible to edit the batch file and perform a sequence of similar runs.

For example, fitting data from several subjects to the same model can be accomplished by creating a batch file during the analysis of the first subject. This batch file can be duplicated for as many subjects as available and edited appropriately.

Another example might to perform a sequence of simulations with different values for selected parameters of the model. Thus you could simulate drug effect after an i.v. bolus administration using a two-compartment model. By editing the resultant batch file the effect of varying some of the parameters can be determined. For example the effect of  $ke_0$  on the Effect versus time curve can be explored.

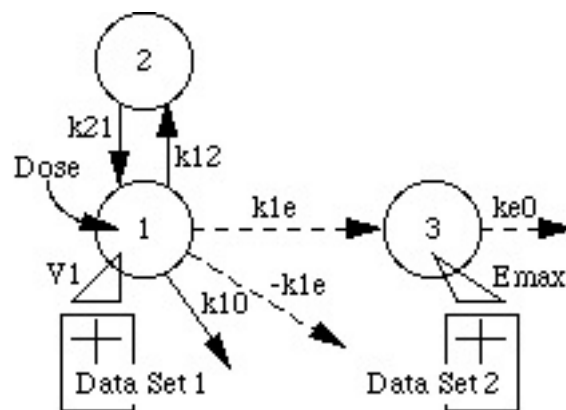

Start Boomer and select Keyboard --> .BAT entry. Select Simulation (2), file output (1) and enter Tutorial\_3 as the output file name. Proceed to parameter definition and entry. Enter each of the parameters from the table below.

Parameters for I.V. Administration Simulation of Concentration and Effect					
Type	Name	Value	To	Data Set Name	From
1	Dose	200	1		1
2	k10	0.2	0		1
2	k12	1.3	2		1
2	k21	1.1	1		2
18	V1	12	1	Cp	1
2	ke0	0.8	0		3
2	k1e	0.067 <sup>1</sup>	3		1
2	-k1e	-0.067 <sup>2</sup>	0		1
11	Effect <sup>3</sup>	100	2	Effect	3
		8			
		1.5			

1	Calculated as double dependent = $ke0/V1$
2	Set equal to a minus k1e from component 1 thus effect compartment has no effect on pharmacokinetic model
3	Emax, EC(e, 50%), and s factor for Effect

After entering all the parameters enter -1. Choose numerical integration method 2 and select the default values for relative and absolute errors. After entering a suitable title enter 1 for data from keyboard and enter time values of 0, 0.5, 1, 2, 3, 4, 6, 9, and 12 hours for each data set. Enter zero for the y-values. Enter 2 to plot the simulated data for concentration in the central compartment and the effect. The batch file Tutorial\_3.BAT includes all the entries needed for this simulation.

After the first simulation, enter -2 to quit the run without exiting the program. Using the editor it is possible to alter the value of  $ke_0$ , save the new batch file and then choose batch file run to the new simulation.

## D. SIMULTANEOUS FIT TO IV AND ORAL DATA - IRWLS

Boomer will allow the simulation and analysis of up to 20 data set lines. Boomer also allows setting a parameter equal to another parameter or pair of parameters. Thus fitting iv and oral data simultaneously is not difficult. Again, the first step is to develop the model on paper. For example a model with separate iv and oral administration is shown in the figure below.

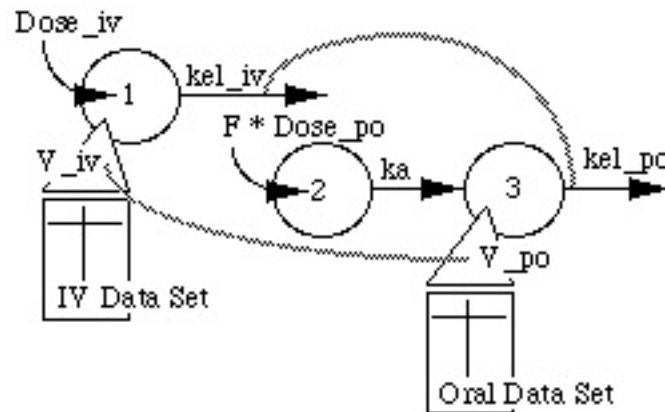

There will be two types of parameter dependencies used to define this model. First, we can set the  $kel_{po}$  and  $V_{po}$  equal to  $kel_{iv}$  and  $V_{iv}$ , respectively. Thus the values of  $kel_{iv}$  and  $V_{iv}$  will be adjustable and the oral parameter values will follow along during the analysis. The second type of dependence is a double dependence. The oral dose and  $F$  value can be set-up as 'dummy' parameter and a type 1 (dose/initial condition) can be set equal to  $F \times Dose_{po}$ . This way the  $dose_{po}$  can be fixed at the dose given and the bioavailability,  $F$ , can be adjustable.

For this tutorial we will use the iteratively reweighted least squares method. This is very similar to the normal fitting method except that the data weight is recalculated during the fitting process as the calculated concentration changes. Additionally the iv and oral data will be read from two disk files, Tutorial\_4iv.DAT and Tutorial\_4po.DAT, respectively.

Start Boomer and select Keyboard entry. Select IRWLS (3), file output (1) and enter Tutorial\_4 as the output file name. Proceed to parameter definition and entry.

Parameters for Simultaneous Fit to IV and Oral Data											
Type	Name	Value	Fixed, Adjust ...	Lower Limit	Upper Limit	D Type	D 1	D 2	To	Data Set Name	From
1	Dose_iv	100	0						1		
2	kel_iv	0.25	1	0	1.0				0		1
18	V_iv	15	1	1	100				1	Cp_iv	1
19 <sup>1</sup>	Dose_po	250	0								
19 <sup>2</sup>	F_po	0.8	1	0.5	1.2						
1	F*Dose_po	200	3 <sup>3</sup>			5	4	5	2		
2	ka_po	2.0	1	0	5				3		2
2	kel_po	0.2	2 <sup>4</sup>				2		0		3
18	V_po	15	2				3		2	Cp_po	3

1	Dummy parameter - Fixed	2	Dummy parameter - Adjustable
3	Double dependence - Parameter 4 x Parameter 5		
4	kel_po = kel_iv		

Enter each of the parameters from the table above. After entering all the parameters enter -1. Choose numerical integration method 2 and select the default values for relative and absolute errors. Choose the simplex fitting algorithm (3) and select the default value for PC. After entering a suitable title enter 0 for data from disk file. Enter disk filenames for the iv data and the oral data, respectively (or select these files from the 'Open' dialog). Choose weight type 2, (1/val<sup>2</sup>), for both data set lines. Once the fitting is complete choose 1 then 2 to calculate the AUC, AUMC, and MRT for the iv and oral data sets. These sets are included in the file Tutorial\_4.BAT.

## E. SIMULATION WITH ERROR AND MONTE-CARLO SIMULATIONS

On occasion it may be useful to simulate models and be able to add error to the data. On other occasions it may be useful to simulate data where the parameters have different, random values. This is possible with the Simulation with Error option. Also, by editing a previously created batch file it is possible to perform many repeated simulations or analyses. In this tutorial you will simulate a two-compartment model after iv bolus administration and add a random

error to the three rate constants. Once the initial batch file is created it will be edited to allow repeated simulation and production of a series of data files.

Start Boomer and select Keyboard entry creating a .BAT file (2). Name this .BAT file, Tutorial\_5. Select Simulation with random error (3), screen output (0). Proceed to parameter definition and entry. Enter each of the parameters from the table below.

Model Parameters for Simulation with Error										
Type	Name	Value	Fixed, Adjust ...	Lower Limit	Upper Limit	Error Type	Intensity Factor	To	Data Set Name	From
1	Dose	100	0					1		
2	k10	0.2	1	0.1	0.3	4 <sup>1</sup>	0.1 <sup>2</sup>	0		1
2	k12	1.5	1	1	2	4	0.1	2		1
2	k21	1.2	1	0.5	2	4	0.1	1		2
18	Y	10	0					1	Cp	1

1	Normal error x Value
2	Standard deviation as a fraction of parameter value

After entering all the parameters enter -1. Choose numerical integration method 2 and select the default values for relative and absolute errors. After entering a suitable title for the run enter the times 0, 0.5, 1, 2, 3, 4, 6, 9, and 12 with zero for the y-value from the keyboard. Accept the data (0) and don't save the data at this point. Enter error type 0 so no error is added to the data calculated. After the simulation enter 0 for the AUC line and 1 to save the calculated data. Enter Tutorial\_5 as the data file name (use tut5 with DOS version) and -2 to finish the simulation run. This gives us an initial simulation run with one data set. The next step is to edit the file, Tutorial\_5.BAT by **adding** a new second line with ` 10'. The first four lines are now:

Boomer Batch File

```
10
4          wls,bayes,sim,irwls,sim+error,grid
0          Screen,diskfile,printer
```

This will cause Boomer to run the simulation 10 times with different values for k10, k12, and k21, each time producing a new Tutorial\_5 x.DAT file where the x is the sequence number.

## F. GRID SEARCH METHOD

The final tutorial will use the grid search method of fitting a set of data. This method breaks the range from lower to upper limit into a number of steps. With more than one parameter a

number of grids are produced and the program will methodically calculate the WSS at each point on each grid. This can be quite slow unless a coarse grid is used. Again using the iv bolus two compartment model you can explore the grid search method by allowing the parameters k12 and k21 to be 'grid searched'.

Start Boomer and select Keyboard entry. Select Grid Search Method (5) and screen output (0). Proceed to parameter definition and entry. Enter each of the parameters from the table below.

Model Parameters for Grid Search									
Type	Name	Value	Fixed, Adjust ...	Lower Limit	Upper Limit	Steps	To	Data Set Name	From
1	Dose	100	0				1		
2	k10	0.2	0				0		1
2	k12	1.25	1	0.5	1.5	10	2		1
2	k21	0.75	1	0.5	1.5	10	1		2
18	Y	10	0				1	Cp	1

After entering all the parameters enter -1. Choose numerical integration method 2 and select the default values for relative and absolute errors. After entering a suitable title enter the data from the keyboard and -1 at the end of data entry. Accept the data and continue without saving. Enter weight type 1 then 1 to save a WSS file to disk. Next enter 20 as the maximum WSS for the grid. Enter a filename for the WSS file, however, only the first three letters are significant. After the run is complete the file Tut01\_02.WSS contains the WSS data in a comma delimited format. Tut01\_02.SFF, a SYLK format file, is also produced. The batch file, Tutorial\_6.BAT, includes the steps required to perform this analysis.

# 7. Error Messages

This section is not exhaustive but is complete to date (i.e. these are error messages that I have seen while running or testing the program). With any large program there may be bugs which arise with unusual (i.e. untested) combinations of input.

## A. FORTRAN ERROR MESSAGES

### 1. *Error 34 - disk full*

May occur during linking or compiling or storing data to a spool file, output to a batch file, or output to a data file. Rerun with a disk containing more room for data. If this occurs during linking or compiling shut-down the system, remove the temporary linker or compiler files and recompile or link).

### 2. *Error 43 - file not found*

Could occur if 1) Running the program from a locked disk and choosing the Print option, retry with the disk unlocked (should be an error 44), 2) User compiled model subroutines are missing, or 3) Data file missing (but calls to INQUIRE should mean this isn't possible).

### 3. *Error 82 - array boundary error*

Possible causes include entry of '0' as the 'from' component on a first order, second order, or a Michaelis-Menten type rate constant. The 'from' component needs to be some number between 1 and 25.

## B. RKF45 ERROR MESSAGES

### 1. *IFLAG = 2*

Normal exit from RKF45. The user will not see any message, just the result.

### 2. *IFLAG = 3*

Relative error too small. Outputted error value may be used when rerunning the program.

### 3. *IFLAG = 4*

More than 500 steps taken to perform the integration. Try rerunning with a larger value for absolute or relative error. Remember the units used internally. For example a dose entered as 1000 mg will mean that 1000 mg will be moved around the system. An absolute error of 0.001 is relatively very small and could probably set somewhat higher without losing any significant accuracy.

### 4. *IFLAG = 5*

Solution vanished. A non-zero absolute error term is required. Increase the value of the absolute error term and retry.

### 5. *IFLAG* = 6

Requested accuracy couldn't be achieved with smallest allowable stepsize. Try using larger values for the error terms.

### 6. *IFLAG* = 7

RKF45 inefficient for this problem. Try larger values for error terms or the Gear method.

### 7. *IFLAG* = 8

Invalid input parameters. Shouldn't occur, possibly there is an error in user defined model.

With *IFLAG* = 3, 4, 6, or 7, this method may be inappropriate. Maybe the system is stiff and the Gear method should be used.

In BATCH mode it is possible to have the program restart automatically after these (*IFLAG* = 5-8) errors.

## F. DIFSUB ERROR MESSAGES

The Gear and Adam methods are automatic, multi-step methods. *JSTART* on exit is equal to the current order used. The maximum values allowed are 7 for the Gear method and 8 for the Adam method.

### 1. *KFLAG* = 1

Normal finish. Not normally seen by the user.

### 2. *KFLAG* = -1

Step was taken with  $h = h_{min}$ , but the requested error was not achieved. Rerun with a larger value for the absolute error.

### 3. *KFLAG* = -2

The maximum order requested was too large. Rerun with larger error value?

### 4. *KFLAG* = -3

Corrector convergence could not be achieved with  $h$  greater than  $h_{min}$ .

### 5. *KFLAG* = -4

Requested error value too small. Try rerunning with a larger value for the error term. Maybe an error in your subroutine CP. If your function is not continuous (multiple dose, an infusion stops or starts) you will need to add an (INIT.eq.-1) section [see below] if you want to use the GEAR method.

In BATCH mode it is possible to have the program restart automatically after these (*KFLAG*  $\neq$  1) errors.

# 8. Acknowledgments

Dr Yamaoka et.al. for writing the original MULTI programs and showing that 'real' pharmacokinetic analysis can be performed on microcomputers.

Trevor Smith for suggesting the RKF45 algorithm for ordinary differential equations.

John Holt for suggesting Gear's method for stiff equations.

Gary Koritz and Richard Bevill for encouragement and evaluation during the early translation stages.

Carl Peck for clearly describing the relevance of Bayesian methods and suggestions regarding weighting methods and plot output.

Ted Triggs for helpful evaluation during later refinement stages of Multi-Forte.

Monty Hampton for suggestions during the development of Boomer.

# 9. Applications

**Charles, B.G., Schneider, J.J., Norris, R.L.G., and Ravenscroft, P.J.** 1987. Temelastine does not affect theophylline pharmacokinetics in normal subjects, *Brit. J. clin. Pharmacol.*, **24**, 673-675

**Kwon, K.I. and Bourne, D.W.A.** 1987. Physiological pharmacokinetic model for distribution and elimination of tenoxicam, *Int. J. Pharm.*, **37**, 219-226

**Bourne, D.W.A. and Hampton, E.M.** 1988. Modeling and Analysis of Pharmacokinetic Data Using Multi-Forte and Boomer, Second Annual Symposium - Frontiers of Pharmacokinetics and Pharmacodynamics, Little Rock AR, 12-14 October

**Clarke, C.R., Short, C.R., Bourne, D.W.A., and Usenik, E.A.** 1989. Subcutaneously implanted tissue chambers -- a pharmacokinetic study, *J. Vet. Pharmacol. Therap.*, **12**, 312-321

Graves, N.M., Homes, G.B., Kriel, R.L., Jones-Saete, C., Ong, B. and Ehresman, D.J. 1989. Relative Bioavailability of Rectally Administered Phenobarbital Solution, *DICP Ann. Pharmacother.*, **23**, 565-568

**Ho, K.Y., Weissberger, A.J., Stuart, M.C., Day, R.O. and Lazarus, L.** 1989. The Pharmacokinetics, Safety and Endocrine Effects of Authentic Biosynthetic Human Growth Hormone in Normal Subjects, *Clin. Endocrin.*, **30**, 335-345

**Ismail, Z., Triggs, E.J., Smithurst, B.A., and Parke, W.** 1989. The pharmacokinetics of amiloride-hydrochlorothiazide combination in the young and elderly, *Eur. J. Clin. Pharmacol.*, **37**, 167-171

**Casto, D.T., Schnapf, B.M., Clotz, M.A.** 1990. Lack of effect of short-term passive smoking on the metabolic disposition of theophylline, *Eur. J. Clin. Pharmacol.*, **39**, 399-402

**Chen, G., Griffin, M., Poyer, J.L., McCay, P.B. and Bourne, D.W.A.** 1990 HPLC procedure for the pharmacokinetic study of the spin-trapping agent,  $\alpha$ -phenyl-N-tert-butyl nitron (PBN), *Free Radical Biology and Medicine*, **9(2)**, 93-99

**Hampton, E.M., Hrdlicka, K. and Bourne, D.W.A.** 1991. Comparison of MS-DOS and Macintosh pharmacokinetic analysis programs using a two-compartment, two-infusion dosing scheme, *Clin. Pharm.*, **10**, 206-209

**Paap, C.M., Nahata, M.C., Mentser, M.A., Mahan, J.D., Puri, S.K. and Hubbard, J.W.** 1991 Pharmacokinetics of cefotaxime and its active metabolite in children with renal dysfunction, *Antimicrob Agents Chemother.*, **35(9)** 1879-1883

**Markowsky, S.J., Zimmerman, C.L., Tholl, D., Soria, I. and Castillo, R.** 1991. Methotrexate Disposition Following Disruption of the Blood-Brain Barrier, *Therapeutic Drug Monitoring*, **13**, 24-31

**Kim, H.C., McMillan, C.W., White, G.C., Bergman, G.E., Horton, M.W., and Saidi, P.** 1992 Purified Factor IX Using Monoclonal Immunoaffinity Technique: Clinical Trials in Hemophilia B and Comparison to Prothrombin Complex Concentrates, *Blood*, **79(3)** 568-57

**Fan-Havarda, P., Koshya, Z., Baisa, R.M., Smith, C. and Eng, R.H.K.** 1993 Effect of morphine or phenobarbital on teicoplanin elimination pharmacokinetics, *Journal of Antimicrobial Chemotherapy*, **32** 101-108

**Paap, C.M. and Nahata, M.C.** 1993 The relation between type of renal disease and renal drug clearance in children, *European Journal of Clinical Pharmacology*, **44(2)** 195-197

**Pallapies, D., Peskar, B.A., Brune, K. and Geisslinger, G.** 1994 Effects on platelet functions and pharmacokinetics of azapropazone and ketorolac tromethamine given as single parenteral doses, *Br J Clin Pharmacol.*, **37(4)** 335-339

**Dachman, W.D., Adubofour, K.O., Bikin, D.S., Johnson, C.H., Mullin, P.D. and Winograd, M.** 1994 Cimetidine-induced rise in praziquantel levels in a patient with neurocysticercosis being treated with anticonvulsants, *The Journal of infectious Disease*, **169** 689-91

**Walker, J.L., Clarke, C.R. , Hague, C.M., Bourne, D.W. and Lessley, B.A.** 1994 Effects of localized *Pasteurella haemolytica* infection on erythromycin-binding properties of bovine alpha-1-acid glycoprotein, albumin, serum, and tissue chamber fluids, *Antimicrob Agents Chemother.*, **38(10)** 2392-2397

**Kobayashi, K., Vokes, E.E., Vogelzang, N.J., Janish, L., Soliven, B. and Ratain, M.J.** 1995 Phase I study of suramin given by intermittent infusion without adaptive control in patients with advanced cancer, *Journal of Clinical Oncology*, **13** 2196-2207

**Lau, C.E., Ma, F., Wang, Y. and Smith, C.** 1996 Pharmacokinetics and bioavailability of midazolam after intravenous, subcutaneous, intraperitoneal and oral administration under a chronic food-limited regimen: relating DRL performance to pharmacokinetics, *Psychopharmacology*, **126(3)** 241-248

**Roder, J.D., Chen, C.L., Chen, H. and Sangiah, S.** 1996 Bioavailability and pharmacokinetics of ibuprofen in the broiler chicken, *Journal of Veterinary Pharmacology and Therapeutics*, **19(3)** 200-204

**Manduru, M., Mihm, L.B., White, R.L., Friedrich, L.V., Flume, P.A. and Bosso, J.A.** 1997 In vitro pharmacodynamics of ceftazidime against *Pseudomonas aeruginosa* isolates from cystic fibrosis patients, *Antimicrob. Agents Chemother.*, **41(9)** 2053-2056

Polikandritou Lambros, M., Bourne, D.W.A., Abbas, S.A., and Johnson, D.L. 1997 Disposition of aerosolized liposomal amphotericin B, *Journal of Pharmaceutical Sciences*, **86(9)** 1066-1069

**Kwon, K-I. and Bourne, D.W.A.** 1997 Gastrointestinal absorption of phenytoin from an oil-in-water microemulsion, *Archives of Pharmacal Research*, **20(5)** 480-485

**Browne, G.S., Nelson, C., Nguyen, T., Ellis, B.A., Day, R.O. and Williams, K.M.** 1999 Stereoselective and substrate-dependent inhibition of hepatic mitochondrial  $\beta$ -oxidation and oxidative phosphorylation by the non-steroidal anti-inflammatory drugs ibuprofen, flurbiprofen, and ketorolac, *Biochemical Pharmacology*, **57(7)** 837-844

**Hakman, M. and Groth, T.** 1999 Object-oriented biomedical system modeling-The Rationale, *Computer methods and programs in biomedicine*, **59(1)** 1-17

**Rusckowski, M., Qu, T., Pullman, J., Marcel, R., Ley, A. C., Ladner, R.C., and Hnatowich, D.J.** 2000 Inflammation and Infection Imaging with a  $^{99m}\text{Tc}$ Neutrophil Elastase Inhibitor in Monkeys, *J. NucI Med*, **41** 363-374

**Alberts, M.K., Clarke, C.R., MacAllister, C.G., and Homer, L.M.** 2000 Pharmacokinetics of acetazolamide after intravenous and oral administration in horses, *American Journal of Veterinary Research* **61(8)** 965-968

**IIIa, E.B., Lehenbauerb, T.W. and Sangiah, S.** 2000 Oral pharmacokinetics of fenbendazole in llamas, South American Camelids, *Small Ruminant Research*, **37(3)** 209-214

**White, R.L., Friedrich, L.V., Manduru, M., Mihm, L.B. and Bosso, J.A.** 2001 Comparative in vitro pharmacodynamics of imipenem and meropenem against ATCC strains of Escherichia coli, Staphylococcus aureus and Bacteroides fragilis, *Diagnostic microbiology and infectious disease*, **39(1)** 39-47

**Kilica, K., Sproule, B.A., Turksen, I.B. and Naranjo, C.A.** 2002 Fuzzy system modeling in pharmacology: an improved algorithm, *Fuzzy Sets and Systems*, **130(2)** 253-264

**Kilic, K., Sproule, B.A., Turksen, I.B. and Naranjo, C.A.** 2004 Pharmacokinetic application of fuzzy structure identification and reasoning, *Information Sciences*, **162(2)** 121-137

Gilmour, M.A., Clarke, C.R., MacAllister, C.G., Dedeo, J.M., Caudell, D.L., Morton, R.J. and Pugh, M. 2005 Ocular penetration of oral doxycycline in the horse, *Veterinary Ophthalmology*, **8** (5) 331-335

**Durisova, M. and DedÁ-k, L.** 2005 New Mathematical Methods in Pharmacokinetic Modeling, *Basic & Clinical Pharmacology & Toxicology*, **96(5)** 335-342

**Homer, L.M., Clarke, C.R. and Weingarten, A.J.** 2005 Effect of dietary fat on oral bioavailability of tepoxalin in dogs, *Journal of Veterinary Pharmacology and Therapeutics*, **28(3)** 287-291

**Pizon, A.F., Becker, C.E. and Bikin, D.** 2007 The Clinical Significance of Variations in Ethanol Toxicokinetics, *J. Medical Toxicology*, **3(2)**, 63-72

Maxwell, L.K., Bentz, B.G., Bourne, D.W.A. and Erkert, R.S. 2008 Pharmacokinetics of valacyclovir in the adult horse, *Journal of Veterinary Pharmacology and Therapeutics*, **31(4)** 312-320

**Goldsmith, M-R., Transue, T.R., Chang, D.T., Tornero-Velez, R., Breen, M.S. and Dary, C.C.** 2010 PAVA: physiological and anatomical visual analytics for mapping of

tissue-specific concentration and time-course data, *Journal Of Pharmacokinetics and Pharmacodynamics*, **37(3)** 277-287